

*armglow*®

## ASSEMBLY & OPERATING INSTRUCTIONS FOR OUTDOOR GAS GRILL

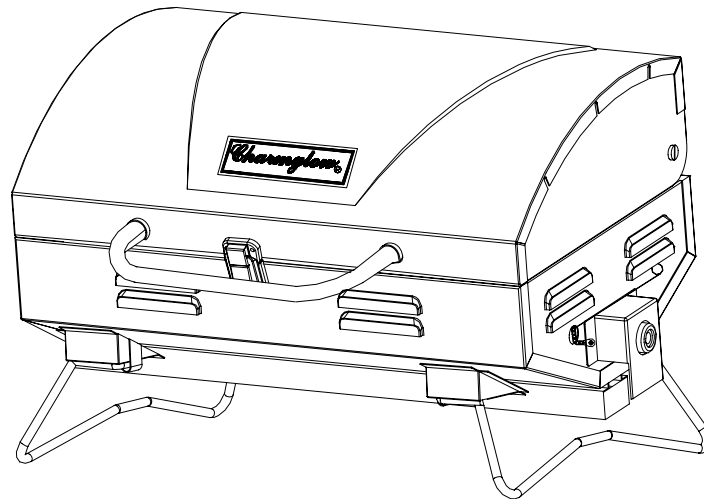

®



### WARNING

To reduce the risk of fire, burn hazard or other injury, read the Care and Use Manual carefully and complete before using your grill.

Model : 820-0002

H16Y06P-1



**PLEASE CONTACT 1-800-913-8999 FOR ASSISTANCE  
DO NOT RETURN TO PLACE OF PURCHASE**



**DANGER**

If you smell gas:

1. Shut off gas to the appliance
2. Extinguish any open flame.
3. Open lid
4. If door continues, keep away from the appliance and immediately call you fire department.

Failure to follow these instructions could result in fire or explosion, which could cause property damage, personal injury or death



**DANGER**

1. Never operate this appliance unattended.
2. Never operate this appliance within 10 feet (3.05m) of any other gas cylinder.
3. Never operate this appliance within 25 feet (75m) of any flammable liquid.
4. Do not fill cooking vessel beyond maximum fill line
5. Never allow oil or grease to get hotter than 400°F (200°C) or if oil begins to smoke, immediately turn the burner or gas supply OFF
6. Heated liquids remain at scalding temperatures long after the cooking process. Never touch cooking appliance until liquids have cooled to 115°F (45°C) or less.
7. If a fire should occur, keep away from the appliance and immediately call your fire department. Do not attempt to extinguish an oil or grease fire with water.

Failure to follow these instructions could result in fire, explosion or burn hazard, which could cause property damage, personal injury or death.

Note: Boxed statements above that are not applicable to a specific appliance may be deleted.

“This appliance is not intended for commercial use.”

Failure to follow these instructions could result in fire or explosion, which could cause property damage, personal injury or death.

# SAVE THESE INSTRUCTIONS

## TABLE OF CONTENTS

Safety Instruction.....	1-3
Illustrated Parts Breakdown.....	4
Parts List.....	4
Assembly Instruction.....	5
Lighting Instruction.....	6
Lighting Rod Assembly Instruction.....	7-8
Care and Maintenance.....	9
Cooking Instruction.....	10
Trouble Shooting.....	11
Limited Warranty.....	12

Read this Care and Use Manual carefully and completely before using your grill to reduce the risk of fire, burn hazard or other injury.

**YOU SAFETY IS VERY IMPORTANT – FAILURE TO FOLLOW PROPER PROCEDURES AND SAFEGUARDS MAY RESULT IN SERIOUS PERSONAL INJURY OR PROPERTY DAMAGE**

# Safety Instructions

READ THE FOLLOWING INSTRUCTIONS CAREFULLY AND BE YOUR GRILL IS PROPERLY INSTALLED, ASSEMBLED AND MAINTAINED. FAILURE TO FOLLOW THESE INSTRUCTION MAY RESULT IN SERIOUS BODILY INJURY AND/ OR PROPERTY DAMAGE. IF YOU HAVE QUESTIONS CONCERNING ASSEMBLY OR OPERATION, CALL OUR SERVICE CENTER AT 1-800-913-8999

LP – gas supply cylinder to be used must be constructed and marked in accordance with the specifications for LP-gas cylinders of the U.S Department of Transportation (DOT) or the National Standard of Canada, CAN-B339, Cylinders, Spheres and Tubes for the Transportation of Dangerous Goods

- The installation must conform with local codes or, in the absence of local codes, with the National Fuel Gas Code, ANSI Z223.1/ NFPA 54, storage and Handling of Liquefied petroleum Gases, ANSI/NFPA 58 or CSA B149 1, Natural Gas and Propane Installation Code.
- This instruction manual contains important information necessary for the proper assembly and safe use of the appliance
- Do not use your gas grill in garages, porches, breezeways, sheds or other enclosed areas. Your gas grill is to be used outdoor only, at least 24 inches from the back and side to any combustible surface. The grill should not be placed under any surface that will burn. Do not obstruct the flow of combustion and ventilation air around the grill housing.
- This instruction manual contains important information necessary for the proper assembly and safe use of the appliance
- Read and follow all warning and instructions before assembling and using the appliance
- Follow all warning and instructions when using the appliance.
- Keep this manual for future reference.
- This grill is not intended to be installed in or on recreational vehicles and / or boats.
- Do not leave children alone or unattended in an area where the grill is being used.
- The use of alcohol, prescription or non-prescription drugs may impair the consumer's ability to properly assemble or safely operate the appliance
- Heated liquids remain at scalding temperatures long after the cooking process. Do not touch the cooking appliance until liquids have cooled to 115°F (45°C) or less
- The appliance will be hot during and after use insulated oven mitts or gloves for protection from hot surfaces or splatter from cooking liquids.
- This appliance is not intended for and should never be used as a heater
- Do not leave the appliance unattended keep children and pets away from the appliance at all times
- Keep any electrical cord of fuel supply hose away from any heated surfaces
- Storage of an outdoor cooking gas appliance indoor is permissible only if the cylinder is disconnected and removed from the outdoor cooking gas appliance
- Do not move the appliance when in use. Allow the grill to cool before moving or storing
- The cylinder must be disconnected when the appliance is not in use.

## The Fuel System

Gas grills are used safely by millions of people when following simple safety precautions.

The items in the fuel system are designed for operation with the Charmglow Table top grill. They must not be replaced with any other brand. (See parts list for replacement items.)

**GAS BURNER:** The gas burner is constructed of tubular stainless steel and should not require maintenance other than inspection for insects/nests inside the air intake slots.

**BURNER VALVE/REGULATOR:** The burner control is actually a regulator/valve assembly. The regulator attaches directly to the end of the burner, which extends out of the right end of the grill by, a 1-pound propane cylinder threads into the regulator. The burner control operates in the following positions indicated by the pointer at the top of the regulator as installed on the grill:

Once the regulator is in as far as it will go, tighten it with a wrench.

OFF - This stops the flow of gas to the burner.

PUSH TO TURN ON - You must push "IN" on the knob to release the knob from the locked "OFF" position. HIGH - This position provides the highest gas flow and hottest cooking temperatures.

MED - This position provides cooking temperatures between HIGH and LOW.

LOW - This position provides the lowest cooking temperatures.

**ONLY A FACTORY SUPPLIED GAS VALVE/REGULATOR SHOULD BE USED.**

See parts list for replacement items.

### LP GAS REGULATOR CAUTION

The gas pressure regulator provided with this appliance must be used. This regulator is equipped with the required orifice and is set for the required outlet pressure for this appliance. This combination of orifice size and pressure regulation specifications provides the cooking performance intended by Charmglow Table Top Grill. Substitution of regulator by any other device or any other manufacturer is dangerous and could result in serious injury.

### LP GAS REGULATOR

The gas pressure regulator is shipped loose and must be installed prior to operating your grill. This is a "slip-fit" requiring no tools. See assembly instructions for proper installation. The regulator may be removed from grill after use. Turn the regulator control knob to the "OFF" position; disconnect LP cylinder and allow the grill to cool for at least 30 minutes prior to removing regulator.

Care should be taken to store the regulator in a clean, secure location when the grill is not in use. The threaded cylinder connection area should be kept clean and free of dust, dirt, sand or any foreign materials. Clean both the regulator and LP cylinder threaded areas prior to connecting cylinder to regulator.

**PROPANE FUEL:** Warning - propane is a flammable gas. Improper handling may result in an explosion and/or fire and serious accident or injury. Your grill is designed to operate with propane (LP) gas only and is equipped with the proper orifice for propane gas.

**Caution:** Do not connect this grill with any gas supply other than propane. Propane gas is heavier than air and settles in lower areas. Make certain adequate ventilation is available when using your grill. The gas cylinder may be stored outside in a well-ventilated area out of the reach of children when the grill is not in use.

**LP GAS CYLINDER:** This grill is designed and intended to be use with a disposable propane cylinder with a nominal fuel weight of 1 lb. Such a cylinder is approximately 4" in diameter and 7" long. The Charmglow Table Top Grill does not include an LP gas cylinder. This must be purchased separately and be supplied at most hardware stores. The cylinder used must be constructed in accordance with the specifications for LP cylinders of the U.S. Department of Transportation (DOT) DOT-39 NRC232/290 MIII.

The LP gas cylinder shall be used only outdoors in a well-ventilated space and not in a building, garage, or any other enclosed area. Charmglow Table Top Grill may be stored indoor if the LP gas cylinder is removed and stored outdoors. The LP gas cylinder (not included) is threaded for connection directly to the gas regulator supplied with this appliance. The LP gas cylinder is provided with a threaded

connection for access directly to the gas regulator supplied with this appliance. Care should be taken when threading the cylinder to the regulator to engage threads correctly to achieve the proper and intended connection. When disconnecting or connecting the gas cylinder, be careful that the regulator does not strike the grill, the ground, or any other surfaces. Replace the protective cap over the threaded cylinder connection when removed from grill. If any difficulty at all occurs when connecting or disconnecting the cylinder to the regulator assembly, contact your local gas supplier for assistance.

When re-connecting the LP gas cylinder to the regulator, be sure to hand-tighten until snug. This connection should be inspected for damage and leak tested after re-connection.

The threaded cylinder connection should be kept clean and free of dust, dirt, and sand or any foreign materials. Clean both regulator and LP cylinder threaded areas prior to connecting cylinder with regulator.

Keep any electrical supply cord or fuel supply hose away from any heated surfaces.

### **COOKING TEMPERATURE SETTINGS**

**HIGH** - Approximately 450 degrees F

**MED** - Approximately 400 degrees F

**LOW** - Approximately 350 degrees F

NOTE: A disposable 1 lb. Cylinder “NEAR EMPTY” can significantly reduce or will significantly reduce internal pressure and may affect the regulator’s capability to accurately control gas flow. This may cause hotter-than-normal cooking temperatures during the final few minutes of cylinder use as it reaches empty.

NOTE: A disposable 1 lb. cylinder will provide approximately 4-6 hours of cooking time with the Charmglow Table Top Grill.

“ Keep the fuel supply house away from any heated surfaces”

“ The cylinder must be disconnected when the appliance is not in use”



Visually check the burner flames prior to each use, the flames should look like this picture, if they do not ,refer to the burner main tenancy part of this manual.

# ILLUSTRATED PARTS BREAKDOWN

## MODEL 820-0002 TABLE-TOP GRILL

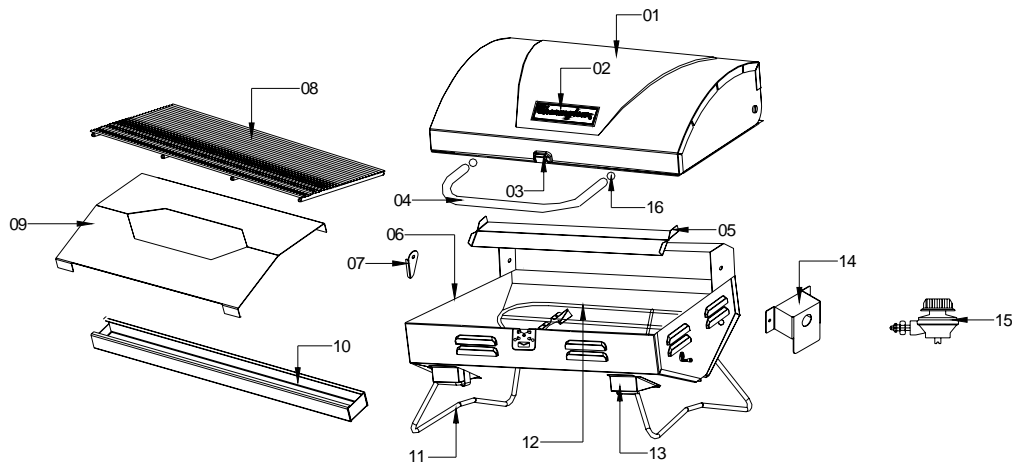

REF#	Description	QTY
1	Main lid	1 PCS
2	Logo	1 PCS
3	Door latch	1 SET
4	Main lid handle	1 PCS
5	Firebox heat shield	1 PCS
6	Main burner bowl assembly	1 PCS
7	Grease tray latch	1 PCS
8	Cooking grid	1 PCS
9	Flame tamer	1 PCS
10	Grease tray	1 PCS
11	Chrome wire legs	2 PCS
12	Main burner	1 SET
13	Leg stator	2 PCS
14	Gas collector box	1 PCS
15	Regulator, LP	1 PCS
16	Main lid handle heat insulating spacer	2 PCS
17	Manual	1 PCS

How to order replacement parts?  
Please call 1-800-913-8999

## Assembly Instruction

PLEASE READ THE INSTRUCTION CAREFULLY AND FOLLOW STEP BY STEP.

Your Charmglow Table Top Grill is pre-assembled. The only part that you need to assemble is to connect gas regulator into your grill. The estimated time for one person to assemble to tabletop grill is 5 to 8 minutes.

1. Locate the gas regulator (1-1). Grasp the regulator (1-1) with the knob (1-2) facing directly up. Line up the collar on the regulator (1-1) with the open end of the burner tube (1-3) as shown in fig.1

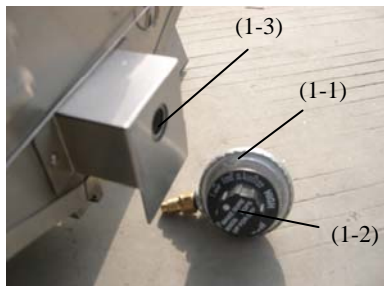

**Fig. 1**

2. Screw the regulator (2-1) into the open end of burner (2-2) as shown in fig. 2

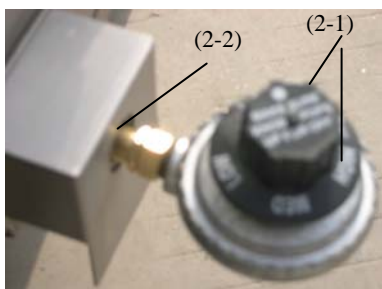

**Fig. 2**

3. Once the regulator is in as far as it will go, tighten with a wrench. Turn the regulator so knob is facing forward.
4. Note: Always make sure the regulator is secured in the fully lock-in position before attaching propane cylinder.
5. Be sure gas control knob (3-1) is in the "OFF" position. Check to make sure threaded areas on cylinder and regulator are clean. Screw the propane cylinder (3-2) onto the regulator (3-3) making sure to engage threads correctly to achieve proper connection. To remove the propane cylinder (3-2) unthread the cylinder from the regulator (3-3) as shown in fig.3

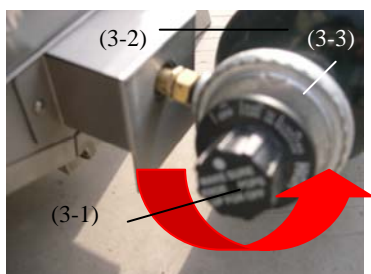

**Fig. 3**



## Lighting Instructions

1. Make sure the regulator is properly secured into the burner end.
2. Make sure the propane cylinder is tightly threaded into the regulator-hand-tighten only.
3. Place stacks in up position.
4. Open lid. Always open lid when lighting.
5. Allow five minutes to get air out.
6. Locate lighting access hole on right side of the panel.
7. Insert match or lighter through access hole next to the burner tube. Keep flame next to burner while actuating gas control knob on regulator.
8. Push gas burner control knob “IN” and turn counter-clockwise to “Lighting Position” while watching burner flame.
9. If ignition does not occur in 3-5 seconds, turn burner off. Wait 5 minutes and repeat the lighting procedure.

Note: If the burner should go out for any reason, turn control knob to “Off” position. Wait 5 minutes before attempting to re-light.

If the grill fails to light after the second attempt, check with your local dealer for assistance.

With the burner lit, gently close lid and allow grill to warm up for 20-30 minutes prior to use.

**Flames should be blue and stable with no yellow tips, excessive noise or lifting. If any of these conditions exist, check to see if the air shutter or burner ports are blocked by dirt, debris, spider webs, etc. If you have any questions regarding flame stability, please call customer service.**



Typical flame pattern and proper flame height.



To adjust for proper flame, use a Phillips screwdriver to loosen screw. Turn clockwise to close the air shutter, and counterclockwise to open. After adjusting, tighten screw to fix air shutter.

# Lightning Rod Assembly Instructions

## TURNING GRILL OFF

1. Open lid.
2. Turn regulator control knob to "OFF".
3. Caution: Do not attempt to re-light without following all lighting instructions.
4. Allow grill body to cool at least 30 minutes before attempting to move or transport.

**PLEASE READ THE INSTRUCTION CAREFULLY AND FOLLOW STEP BY STEP.**

1. Please locate the lightning rod located on the right side of your tabletop grill. Please see the following figure.

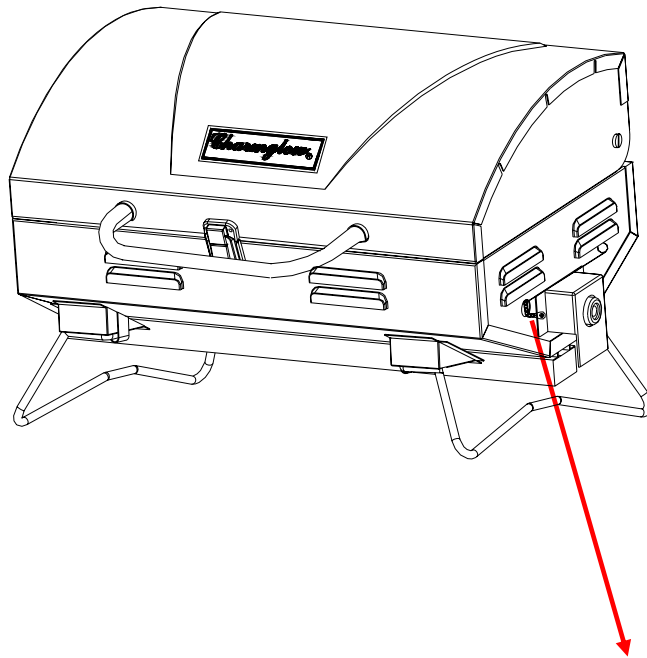

Lightning Rod

2. Please attach the match to the front end of the lightning rod, and stick the lightning rod into the access to manual lighting hole to light the fire as indicated in below picture.

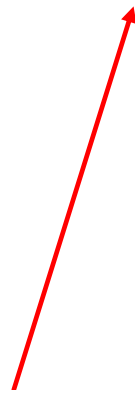
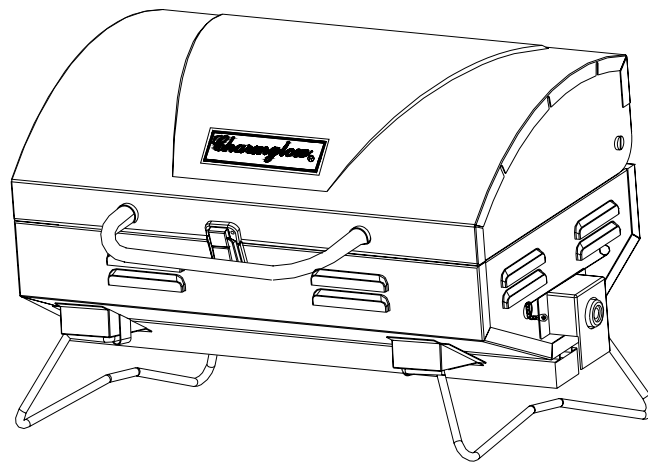

Access to manual lighting

## Care & Maintenance

There is very little care and maintenance needed. The Charmglow Table Top Grill is designed and made of materials that will last many years with normal use. Following these instructions will improve the longevity and quality of cooking. To ensure safe operation of your grill, the area of cooking should always be kept free of combustible materials of any type, such as gasoline or other flammable vapors or liquids.

1. Outside Grill Parts - This is stainless steel. It can be cleaned easily with warm soapy water or any stainless steel cleaner.
2. Cooking Grid and Grease Tray – The cooking grid is made of the high quality stainless steel. The cooking grid should be brushed with a steel brush immediately after cooking, while the grill is still warm. The grease tray is also stainless and can be cleaned with a flat scraper such as a putty knife. **Caution:** The grease tray must be kept clean and free of heavy build up for the grill to perform properly and to eliminate flare - ups
3. Firebox - Use warm soapy water to clean this area. Do not allow grease to build up.
4. Drain Hole – The drain hole must be kept clear of grease and food particles to allow drippings to drain properly into the grease tray. This must be done to maintain proper operation of your grill.
5. General - This grill, like all equipment, will look better and last longer if kept out of weather when not in use. **Caution:** Do not store propane cylinders in enclosed spaces. When using a cover or moving the grill; always wait until the grill has cooled for at least 30 minutes.

**This unit must be kept in an area clear and free from combustible materials, gasoline and other flammable vapors and liquids.**

Make sure all openings into grill body are free of blockages or debris. Make sure there are no objects or materials blocking the flow of combustion or ventilation. Make sure the stacks are in the up position when using the grill.

Check burner air inlet openings (behind inlet guard on right end of body) for insect nests or blockages. Make sure the slots in burner tube are open

When grill is not use, turn the control knob to the “OFF,” position and remove the propane cylinder from the regulator. Remove the regulator from the burner

For outdoor use only, if stored indoors, detach propane cylinder and store outdoors. Propane cylinders must be stored out of reach of children.

Not obstructing the flow of combustion and ventilation air

A clogged tube can lead to a fire beneath the appliance

### **Important**

First-time use. It is important that the grill be lit and allowed to operate at least 30 minutes before any food is placed on the cooking grid. It is normal for some smoke to appear during the initial operation of the grill. After initial heating, the grill is ready for use. A cooking spray can be used on the cooking grids to allow easier clean up

**THIS COOKING APPLIANCE IS FOR OUTDOOR USE ONLY AND SHALL NOT BE USED IN A BUILDING, GARAGE OR ANY OTHER ENCLOSED AREA.**

### **MOVING INSTRUCTIONS**

**Caution: Never move the grill with burner lit**

Make sure control knob is in the “OFF”. Disconnect propane cylinder from regulator. Remove regulator from grill. Be sure grill has completely cooled for at least 30 minutes. Close lid and secure latch. Place stacks in down position if necessary. Carry grill by handle between stacks.

**Note:** It is best to leave the grease pan in place attached to the bottom of the grill-some grease may continue to drip from drainpipe during transport.

## Cooking Instructions

1. Allow grill to warm up with lid closed for 20-30 minutes prior to cooking.
2. This Charmglow Table Top Grill model is equipped with an adjustable HIGH/MED/LOW burner control. This allows for complete flexibility in cooking temperatures.

HIGH setting has a cooking temperature of approximately 450 degrees F.

MED is approximately 400 degrees F.

LOW is approximately 350 degrees F.

3. The cooking times we suggest are only that-suggestions. You may want to vary the times as you become used to your grill.
4. You may cook on the grill in any weather. If the temperature is extremely cold or hot, it will slightly decrease or increase your cooking times. Keep grill out of reach of excessive winds when operating, as it may increase cooking times.

### GRILLING

1. Steak-T-bone, thick, medium: grill 10 minutes on each side at MED setting.
2. Chicken Quarters, average size fryer: Cook skin side up for 30 minutes and skin side down for 30 minutes at MED setting. Check for doneness. If chicken is completely done, only then dip or brush on the sauce or your choice. Put back on grill for approximately 10 minutes longer. Note: You may want to repeat this process one or two more times.
3. Pork ribs and pork chops; grill 10-20 minutes on each side, MED setting. When done, drip or brush on sauce. Put back on grill for 5-10 minutes. Repeat if desired.

### GRILLING INSTRUCTIONS

1. Fish grilling: Allow grill to warm up for 15 minutes. Place fish on grill and season to taste. Allow 20-30 minutes total grilling time, turning at half the grilling time if desired (turning is not necessary).
2. Chicken halves or quarters: Place on grill for 60 minutes. Turn off at 30 minutes if desired.
3. Steak - -thick: Allow grill to warm for 15 minutes, and then place steaks on grill. Allow 6-10 minutes per side. The minutes on each side will produce medium-well to well-done steaks.
4. Hamburger: same as steak.
5. Ribs: Allow grill to warm up for 15 minutes, place ribs on grill. Allow 40-60 minutes grilling time. Turn at half the grilling time if desired not necessary). Baste or dip in sauce at any time.
6. Whole chicken: Allow grill to warm up. Season chicken with seasoning mix. Grill for 1-1/2 hours.
7. Turkey breast: Allow grill to warm up. Grill 10 minutes per pound or until internal temperature reaches 170° F.

## TROUBLE SHOOTING



**WARNING** Spiders and insects can nest inside the burners of the grill and disrupt gas flow. This very dangerous condition could cause a fire behind the valve panel, thereby damaging the grill and making it unsafe for operation. Inspect the grill at least twice a year

### When to Look for Spiders

You should inspect the burners at least twice a year or immediately after any of the following conditions occur:

1. The smell of gas in conjunction with burner flames appearing yellow.
2. The grill does not reach temperature.
3. The grill heats unevenly
4. The burners make popping noises.

### BEFORE CALLING FOR SERVICE

#### PROBLEMS

Grill won't light when the control knob is turned to on.

#### WHAT TO DO

Check to see if the tank is empty.

Check burner ports for any blockage. Use soft wire brush to clear plugged ports.

Check the gas orifice on the malfunctioning burner for an obstruction.

If orifice is blocked, Clean it with a needle or a thin wire. NEVER USE A WOODEN PICK.

Burner flame is yellow or orange, in conjunction with the odor of gas.

Call our customer service line 1-800-913-8999.

Low heat with knob in "HI" position.

Is the fuel hose bent or kinked?

Is the grill in a dusty area?

Is there adequate gas supply available?

If it is only one burner that appears low, does the orifice or burner need cleaning?

Is the gas supply, or gas pressure low?

Is the grill being preheated for 15 minutes?

If the grill does not function properly, use the following checklist before contacting your dealer for service.

**LIMITED WARRANTY  
MODEL 820-0002  
STAINLESS STEEL OUTDOOR GAS GRILL**

*Nexgrill Industries, Inc.* warrants to the original consumer purchaser of each Charmglow Outdoor Gas Grill that when subject to normal residential use, it is free from defects in workmanship and materials for the periods specified below. This warranty excludes grills used in rental or commercial applications.

<b>Component</b>	<b>Warranty Period:</b>
Burners:	3 Years
Stainless Steel Flame Tamer:	2 Years
Stainless Steel Cooking Grids:	3 Years
Regulator	1 Year
All Stainless Steel Parts	3 Years

Our obligation under this warranty is limited to repair or replacement, at our option, of the product during the warranty period. The extent of any liability of Nexgrill Industries, Inc under this warranty is limited to repair or replacement. This warranty does not cover normal wear of parts, discoloration of the stainless steel parts, or damage resulting from any of the following: negligent use or misuse of the product, use on improper fuel/gas supply, use contrary to operating instructions, or alteration by any person other than our factory service center. The warranty period is not extended by such repair or replacement.

**Warranty claim procedure:** If you require service or parts for your grill, please contact our Warranty Service Center for factory direct assistance. Our hours of operation are 7 AM to 6 PM PST Monday to Friday, 8 AM to 12 PM PST on Saturday. Our number is 1-800-913-8999 and our FAX number is 1-800-598-8829. Please direct all correspondence to: Nexgrill Industries, Inc. 280 Machlin Court, City of Industry, CA 91789 ATTN: Warranty Service Center. Model 820-0002.

Product repair as provided under this warranty is your exclusive remedy. Nexgrill Industries, Inc. shall not be liable for any incidental or consequential damages for breach of any express or implied warranty on its products. Except to the extent prohibited by applicable law, any implied warranty of merchantability or fitness for a particular purpose on this product is limited to the duration of the above warranty. Some states do not allow the exclusion or limitation of incidental or consequential damages, or allow limitations on how long an implied warranty lasts, so the above limitations or exclusions may not apply to you. This warranty gives you specific legal rights, and you may have other rights, which vary from state to state.