



# Outdoor Gas Grill Operating Instruction

Pages 2 - 18

## 戶外瓦斯烤爐操作說明

頁數 19 - 34

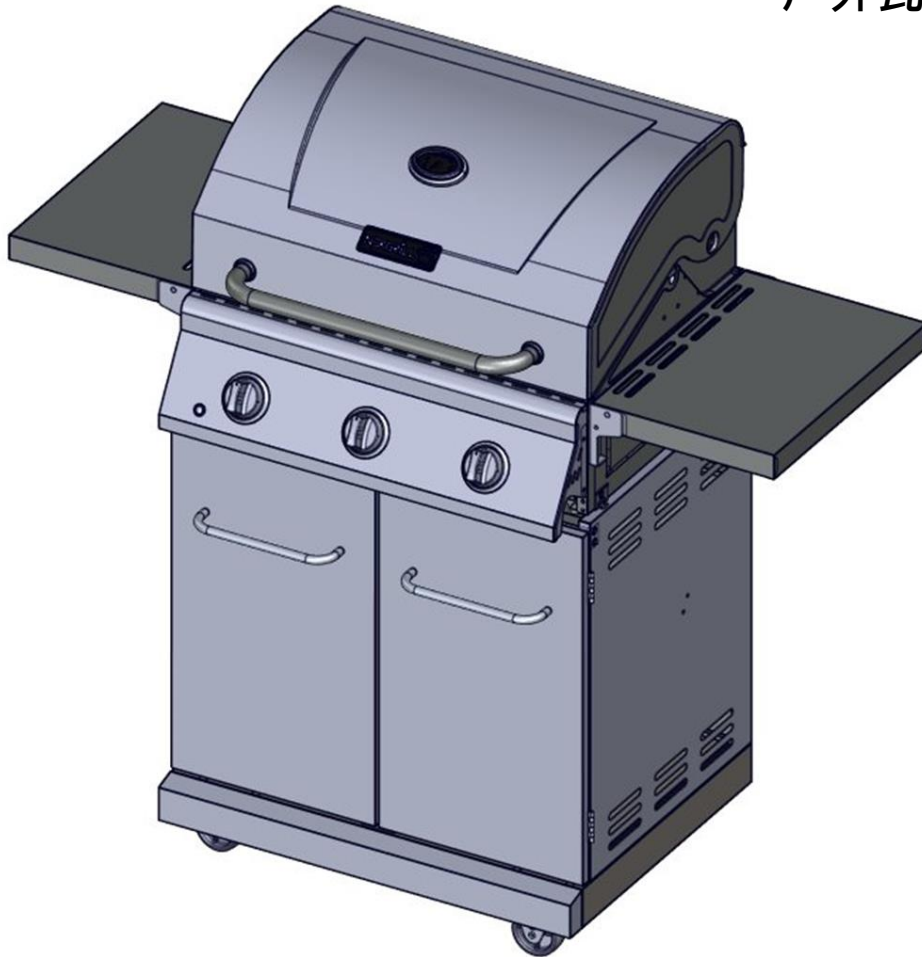

**720-0830MH**  
**ITM. / ART. 1902208**

SERIAL # \_\_\_\_\_ MFG. DATE \_\_\_\_\_ PURCHASE DATE: \_\_\_\_\_  
序列號: \_\_\_\_\_ 製造日期: \_\_\_\_\_ 購買日期: \_\_\_\_\_

- **This instruction manual contains important information necessary for the proper assembly and safe use of the appliance.**
- **Read and follow all warnings and instructions before assembling and using the appliance.**
- **Keep this manual for future reference.**



**Questions, problems, missing parts?** For replacement part, contact call our customer service department at 1- 866-984-7455 in USA and 1-800-648-5864 in Canada, language spoken: English, French, Spanish 8 a.m.-5 p.m., PST. Monday-Friday. [CostcoService@grillservices.com](mailto:CostcoService@grillservices.com).

**FOR OUTDOOR USE ONLY. NOT FOR COMMERCIAL USE.**

僅供戶外使用。非商業用途。

19000805A0

- 本使用手冊內含正確組裝及安全使用所須的重要資訊。
- 在組裝及使用本裝置之前請閱讀及遵照所有警告及指示說明。
- 本手冊請妥為留存以便日後參考使用。

**遇到難題、有疑問或是遺失零件嗎？**



需要更換零件，請與我們的客服部門聯絡，美國當地請撥：1-866-984-7455，加拿大當地請撥：1-800-648-5864，我們提供英語、西語、法語的服務。來電請於太平洋標準時間，禮拜一至禮拜五上午8點至下午5點。或寄送電子郵件至：[CostcoService@grillservices.com](mailto:CostcoService@grillservices.com)。

## Table of Contents

Safety Instruction . . . . .	<b>3</b>	Troubleshooting . . . . .	<b>12</b>
Gas Hook-Up . . . . .	<b>7</b>	Ordering Parts . . . . .	<b>13</b>
Installer Final Check List. . . . .	<b>7</b>	Grill Cooking Chart . . . . .	<b>14</b>
Leak Testing . . . . .	<b>8</b>	Grill Recipe Suggestion . . . . .	<b>16</b>
Operating Instructions . . . . .	<b>9</b>	Limited Warranty . . . . .	<b>18</b>
Lighting Instructions . . . . .	<b>9</b>	Exploded View . . . . .	<b>35</b>
Care and Maintenance . . . . .	<b>11</b>	Part List . . . . .	<b>36</b>

## DANGER

If you smell gas:

- Shut off gas to the appliance.
- Extinguish any open flame.
- Open lid.
- If odor continues, keep away from the appliance and immediately call your gas supplier or your fire department.

## WARNING

1. Do not store or use gasoline or other flammable liquids or vapors in the vicinity of this or any other appliance.
2. An LP cylinder not connected for use shall not be stored in the vicinity of this or any other appliance.

## DANGER

1. Never operate this appliance unattended.
2. Never operate this appliance within 3.05 m / 10 ft. of any structure, combustible material or other gas cylinder.
3. Never operate this appliance within 7.62 m / 25 ft. of any flammable liquid.
4. Do not fill cooking vessel beyond maximum fill line.
5. Heated liquids remain at scalding temperatures long after the cooking process. Never touch cooking appliance until liquids have cooled to 46°C / 115°F or less.
6. This appliance is not intended for and should never be used as a heater.
7. If a fire should occur, keep away from the appliance and immediately call your fire department. Do not attempt to extinguish an oil or grease fire with water.

 Failure to comply with these instructions could result in a fire or explosion that could cause serious bodily injury, death, or property damage.

 Your grill will be very hot. Never lean over the cooking area while using your grill. Do not touch cooking surfaces, grill housing, lid or any other grill parts while the grill is in operation, or until the gas grill has cooled down after use.

**⚠ WARNING**

Do not try lighting this appliance without reading the "LIGHTING INSTRUCTIONS" section of this manual.

TESTED IN ACCORDANCE WITH CNS 13604 FOR GAS BURNING COOKING APPLIANCES FOR DOMESTIC USE.

**Correct LP Gas Tank Use**

LP gas grill models are designed for use with a standard 9 kg / 20 lb. Liquid Propane Gas tank is not included with grill. **Never** connect your gas grill to an LP gas tank that exceeds this capacity.

**NOTE:** The normal flow of gas through the regulator and hose assembly can create a humming noise. A low volume of noise is perfectly normal and will not interfere with operation of the grill. If humming noise is loud and excessive you may need to purge air from the gas line or reset the regulator excess gas flow device. This purging procedure should be done every time a new LP gas tank is connected to your grill.

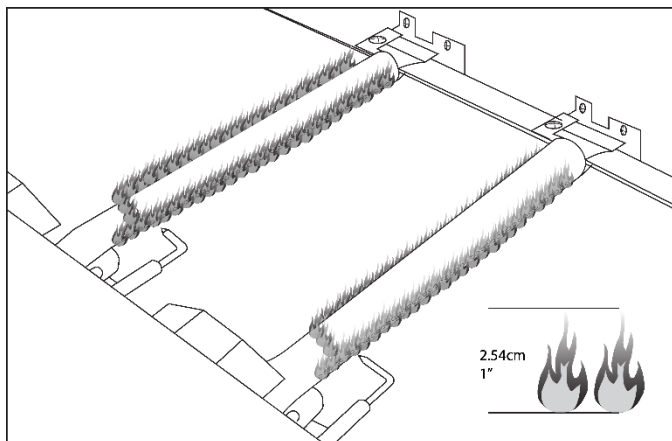

Visually check the burner flames prior to each use. The flames should look like this picture. If they do not, refer to the burner main tenancy part of this manual.

**CAUTION: Beware of Flashback**

**CAUTION:** Spiders and small insects occasionally spin webs or make nests in the grill burner tubes during transit and warehousing. These webs can lead to gas flow obstruction, which could result in a fire in and around burner tubes. This type of fire is known as "FLASH-BACK" and can cause serious damage to your grill and create an unsafe operating condition for the user.

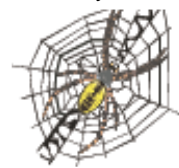

Although an obstructed burner tube is not the only cause of "FLASH-BACK", it is the most common cause.

To reduce the chance of "FLASH-BACK", you must clean the burner tubes before assembling your grill, and at least once a month in late summer or early fall when spiders are most active. Also perform this burner tube cleaning procedure if your grill has not been used for an extended period of time. A clogged tube can be lead to a fire beneath the grill.

## LP-Gas Supply System

- If the information is not followed exactly, a fire resulting in death or serious injury could occur.
- A 9 kg / 20 lb tank of approximately 304.8 mm / 11.9 in diameter by 469.9 mm / 18.49 in high is the maximum size LP gas tank to use.
- The LP gas tank must have a shutoff valve terminating in an LP valve outlet that is compatible with a Type 1. LP gas supply cylinder must have a shut off valve terminating in a valve outlet specified for connection type POL in the standard for compressed gas cylinder valve outlet. LP gas supply cylinder must be fitted with an Overfill Protection Device (O.P.D) The LP gas tank must also have a safety relief device that has a direct connection with the vapor space of the tank. This safety feature prevents the tank from being overfilled, which can cause malfunction of the LP gas tank, regulator and/or grill.
- The tank supply system must be arranged for vapor withdrawal.
- The LP gas tank used must have a collar to protect the tank valve.
- Place dust cap on cylinder valve outlet whenever the cylinder is not in use. Only install the type of dust cap on the cylinder valve outlet that is provided with the cylinder valve. Other types of cap or plugs may result in leakage of propane.
- Never connect an unregulated LP gas tank to your gas grill.
- This outdoor cooking gas appliance is equipped with a high capacity hose/regulator assembly for connection to a standard 9 kg / 20 lb Liquid propane cylinder.
- Have your LP gas tank filled by a reputable propane gas dealer and visually inspected and re-qualified at each filling.
- Do not store a spare LP gas cylinder under or near this appliance.
- Never fill the cylinder beyond 80 percent full.
- Always keep LP gas tanks in an upright position.
- Do not store or use gasoline or other flammable vapors and liquids in the vicinity of this or any other appliance.
- Storage of an outdoor cooking gas appliance indoors is permissible only if the cylinder is disconnected and removed from the outdoor cooking gas appliance.
- When your gas grill is not in use the gas must be turned off at LP gas tank.

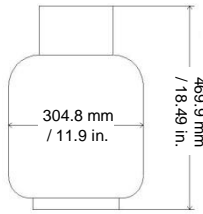

## Proper Placement And Clearance Of Grill

- Never use your gas grill in a garage, porch, shed, breezeway or any other enclosed area. Your gas grill is to be used outdoors only.  
Do Not install this unit into combustible enclosures. Minimum clearance from sides and back of unit to combustible construction, 91 cm / 35.8 in. from sides and 91 cm / 35.8 in. from back.

- **DO NOT** use this appliance under overhead combustible surfaces. This outdoors cooking gas appliance is not intend to be installed in or on recreational vehicles and/or boats.
- LP gas tank must be stored outdoors in a well-ventilated area and out of reach of children. Disconnected LP gas tanks must not be stored in a building, garage or any other enclosed area.
- Do Not obstruct the flow of ventilation air around the gas grill housing. Only use the regulator and the hose assembly supplied with your gas grill. Replacement regulators and hose assemblies must be those specified in this manual.
- The regulator and hose assembly must be inspected before each use of the grill. If there is excessive abrasion or wear or if the hose is cut, it must be replaced prior to the grill being put into operation. The replacement hose assembly shall be that specified by the manufacturer.
- Pressure regulator and hose assembly supplied with the outdoor cooking gas appliance must be used. Never substitute other types of regulator. Contact customer service for manufacturer specified replacement parts.
- This outdoor cooking gas appliance is equipped with a pressure regulator comply with the standard for Pressure Regulating Valves for LP Gas ANSI/ UL 144.
- Do not use briquettes of any kind in the grill.
- The grill is designed for optimum performance without the use of briquettes. Do not place briquettes on the radiant as this will block off the area for the grill burners to vent. Adding briquettes can damage ignition components and knobs, and void the warranty.
- Keep the back and side cart free and clear from debris. Keep any electrical supply cord, or the rotisserie motor cord away from the heated areas of the grill.
- Never use the grill in extremely windy conditions. If located in a consistently windy area (oceanfront, mountaintop, etc.) a windbreak will be required. Always adhere to the specified clearance.
- Never use a dented or rusty propane tank.
- Keep any electrical supply cord and the fuel supply hose away from any heated surface.
- While lighting, keep your face and hands as far away from the grill as possible.
- Burner adjustment should only be performed after the burner have cooled.

### **WARNING**

Your grill will get very hot. Never lean over the cooking area while using your grill. Do not touch cooking surfaces, grill housing, lid or any other grill parts while the grill is in operation, or until the gas grill has cooled down after use.

**Failure to comply with these instructions may result in serious bodily injury.**

**CAUTION:** TO ENSURE CONTINUED PROTECTION AGAINST RISK OF ELECTRIC SHOCK, CONNECT TO PROPERLY GROUNDED OUTLETS ONLY, TO REDUCE THE RISK OF ELECTRIC SHOCK, KEEP EXTENSION CORD CONNECTION DRY AND OFF THE GROUND.

**⚠ WARNING**

Keep a spray bottle of soapy water near the gas supply valve and check the connections before each use.

**⚠ WARNING**

This outdoor cooking gas appliance is not intended to be installed in or on boats. And other recreational vehicles.

**DO NOT USE ALUMINUM FOIL TO LINE THE GRILL RACKS OR GRILL BOTTOM.**

This can severely upset combustion airflow or trap excessive heat in the control area.

**SAFETY PRACTICES TO AVOID PERSONAL INJURY**

When properly cared for your grill will provide safe, reliable service for many years. However, extreme care must be used as the grill produces intense heat that can increase accident potential. When using this appliance basic safety practices must be followed, including the following:

Do not repair or replace any part of the grill unless specifically recommended in this manual. All other service should be referred to a qualified technician.  
This grill is not intended to be installed in or on recreational vehicles or boats.

Children should not be left alone or unattended in an area where the grill is being used. Do not allow them to sit, stand or play in or around the grill at any time.  
Do not store items of interest to children around or below the grill.

Do not permit clothing, pot holders or other flammable materials to come in contact with or too close to any grate, burner or hot surface until it has cooled. The fabric could ignite and cause personal injury.

For personal safety, wear proper apparel. Loose fitting garments or sleeves should never be worn while using this appliance. Some synthetic fabrics are highly flammable and should not be worn while cooking.

Only certain types of glass, heat-proof glass ceramic, earthenware, or other glazed utensils are suitable for grill use. These materials may break with sudden temperature changes. Use only on low or medium heat settings in accordance with the manufacturer's guidelines.

Do not heat unopened food containers. A build-up of pressure may cause the containers to burst.

Use a covered hand when opening the grill lid.  
Never lean over an open grill.

When lighting a burner, pay close attention to what you are doing. Make certain you are aware of which burner you are lighting, so your body and clothing remain clear of open flames.

When using the grill, do not touch the grill rack, burner grate or immediate surroundings as these areas become extremely hot and could cause burns. Use only dry potholders. Moist or damp potholders on hot surfaces may cause steam burns. Do not use a towel or bulky cloth in place of potholders. Do not allow potholders to touch hot portions of the grill rack.

Grease is flammable. Let hot grease cool before attempting to handle it. Do not allow grease deposits to collect in the grease tray at the bottom of the grill's firebox. Clean the grease tray often

Do not use aluminum foil to line the grill racks or grill bottom. This can severely upset combustion air flow or trap excessive heat in the control area.

For proper lighting and performance of the burners keep the burner ports clean. It is necessary to clean them periodically for optimum performance. The burners will only operate in one position and must be mounted correctly for safe operation.

Clean the grill with caution. To avoid steam burns, do not use a wet sponge or cloth to clean the grill while it is hot. Some cleaners produce toxic fumes or can ignite if applied to a hot surface.

Turn off grill controls and make certain the grill is cool before using any type of aerosol cleaner on or around the grill. The chemical that produces the spraying action could, in the presence of heat, ignite or cause metal parts to corrode.

Do not use the grill to cook excessively fatty meats or other products which promote flare-ups.

Do not operate the grill under unprotected combustible constructions. Use only in well ventilated areas. Do not use in buildings, garages, sheds, breezeways or other such enclosed areas.

Keep the area surrounding the grill free from combustible materials including, fluids, trash, and vapors such as gasoline or charcoal lighter fluid. Do not obstruct the flow of combustion and ventilation air.

**NEVER CONNECT AN UNREGULATED GAS SUPPLY LINE TO THE APPLIANCE. USE THE REGULATOR/HOSE ASSEMBLY SUPPLIED.**

This is a liquid propane configured grill. Do not attempt to use a natural gas supply unless the grill has been reconfigured for natural gas use.  
Total gas consumption (per hour) of this stainless steel gas grill with all burners on **⊕** :

<u>Main burner</u>	<u>3 x 4 kW/hr.</u>
<b>Total</b>	<b>12 kW/hr.</b>

## L.P. TANK REQUIREMENT

A dented or rusty L.P. tank may be hazardous and should be checked by your L.P. supplier. Never use a cylinder with a damaged valve. The cylinder supply system must be arranged for vapor withdrawal. The cylinder must include a collar to protect the cylinder valve.

Manifold pressure: 2.8 kPa

## L.P. GAS HOOK-UP

Ensure that the black plastic grommets on the LP cylinder valve are in place and that the hose does not come into contact with the grease tray or the grill head.

## CONNECTION

Your stainless steel grill is equipped with gas supply orifices for use only with liquid propane gas. It is also equipped with a high capacity hose/regulator assembly for connection to a standard 9 kg / 20 lb. L.P. cylinder (469.9 mm / 18.49 in. high, 304.8 mm / 11.9 in. diameter).

All replacement regulators used shall supply propane gas to an outlet pressure of 2.8 kPa.

To connect the L.P. gas supply cylinder, please follow the steps below:

1. Make sure tank valve is in its full off position (turn clockwise to stop)
2. Check tank valve to assure it has proper external male threads

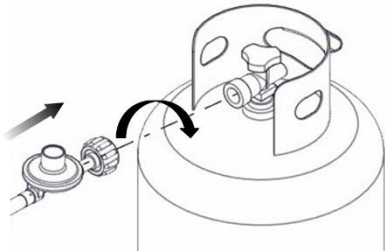

3. Make sure all burner valves are in their off position.
4. Inspect valve connections, port, and regulator assembly. Look for any damage or debris. Remove any debris. Inspect hose for damage. Never attempt to use damaged or obstructed equipment. See your local L.P. gas dealer for repair.
5. When connecting regulator assembly to the valve, hand tighten the quick coupling nut clockwise to a complete stop. Do not use a wrench to tighten. Use of a wrench may damage the quick coupling nut and result in a hazardous condition.
6. Open the tank valve fully (counterclockwise). Apply the soap solution with a clean brush to all gas connections. See below. If growing bubbles appear in the solution the connections are not properly sealed. Check each fitting and tighten or repair as necessary.
7. If you have a gas connection leak you cannot repair, turn gas OFF at supply tank, disconnect fuel line from your grill and call 1- 866-984-7455 in USA and 1-800-648-5864 in Canada or your gas supplier for repair assistance.
8. Also apply soapy solution to the tank seams. See below. If growing bubbles appear, shut tank OFF and do not use or move it! Contact an LP gas supplier or your fire department for assistance.

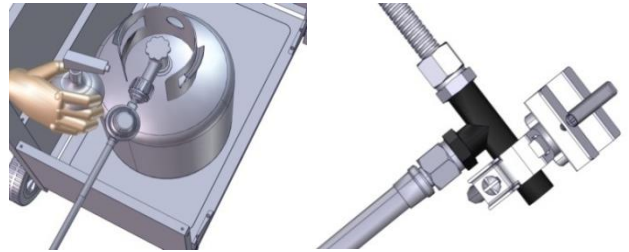

To disconnect L.P. gas cylinder:

1. Turn the burner valves off.
2. Turn the tank valve off fully (turn clockwise to stop).
3. Detach the regulator assembly from the tank valve by turning the quick coupling nut counterclockwise.

## Installer Final Check List

- ✓ **Minimum clearance from sides and back of unit to combustible construction, 91 cm / 35.8 in. from sides and 91 cm / 35.8 in. from back**
- ✓ **All internal packaging removed.**
- ✓ **Knobs turn freely.**
- ✓ **Burners are tight and sitting properly on orifices.**
- ✓ **Pressure regulator connected and set. Gas connections to grill using hose & regulator assembly provided (pre-set for 2.8 kPa / 11 in. water column).**
- ✓ **Unit tested and free of leaks.**
- ✓ **User informed of gas supply shut off valve location**

**USER, PLEASE RETAIN THIS MANUAL FOR FUTURE REFERENCE.**

### PROPANE CYLINDER CAUTIONS

- a) **Do Not store a spare LP-gas cylinder under or near this appliance.**
- b) **NEVER fill the cylinder beyond 80 percent full.**
- c) **If the information in "a" and "b" is not followed exactly, a fire or explosion causing death or serious injury may occur.**

## GENERAL

Although all gas connections on the grill are leak tested at the factory prior to shipment, a complete gas leak test check must be performed at the installation site due to possible mishandling in shipment, or excessive pressure unknowingly being applied to the unit. Periodically check the whole system for leaks following the procedures listed below. If the smell of gas is detected at anytime you should immediately check the entire system for leaks.

## BEFORE TESTING

Make sure that all packing material is removed from the grill including tie-down straps.

**DO NOT SMOKE WHILE LEAK TESTING.**  
**NEVER PERFORM LEAK TEST WITH AN OPEN FLAME.**

Make a soap solution of one part liquid detergent and one part water. You will need a spray bottle, brush, or rag to apply the solution to the fittings. For the initial leak test, make sure the L.P. cylinder is 80% full.

## TO TEST

1. Make sure the control valves are in the "O" position, and turn on the gas supply.
2. Check all connections from the L.P. gas regulator and supply valve up to and including the connection to the manifold pipe assembly (the pipe that goes to the burners). Soap bubbles will appear where a leak is present.
3. If a leak is present, immediately turn off the gas supply and tighten the leaky fittings.
4. Turn the gas back on and recheck.
5. Should the gas continue to leak from any of the fittings, turn off the gas supply and contact customer service at 1- 866-984-7455 in USA and 1-800-648-5864 in Canada, language spoken: English, French, Spanish 8 a.m.-5 p.m., PST. Monday-Friday.

**ALWAYS CHECK FOR LEAKS AFTER EVERY L.P. TANK CHANGE**

**Check all gas supply fittings for leaks before each use. It is handy to keep a spray bottle of soapy water near the shut-off valve of the gas supply line. Spray all the fittings. Bubbles indicate leaks.**

**Your grill is ready to use!**



Only those parts recommended by the manufacturer should be used on the grill.

Substitution will void the warranty. Do not use the grill until all connections have been checked and do not leak.

## GAS FLOW CHECK

Each grill burner is tested and adjusted at the factory prior to shipment; however, variations in the local gas supply may make it necessary to adjust the burners. The flames of the burners should be visually checked.

Flames should be blue and stable with no yellow tips, excessive noise or lifting. If any of these conditions exist, check to see if the air shutter or burner ports are blocked by dirt, debris, spider webs, etc. If you have any questions regarding flame stability, please call customer service 1- 866-984-7455 in USA and 1-800-648-5864 in Canada, language spoken: English, French, Spanish 8 a.m.-5 p.m., PST. Monday-Friday.



# Operating Instructions

## GENERAL USE OF THE GRILL

Each main burner is rated at 4.00 kW/HR. The main grill burners encompass the entire cooking area and are side ported to minimize blockage from falling grease and debris. The knobs are located on the lower center portion of the control panel. Each knob is labeled on the control panel.

## USING THE GRILL

Grilling requires high heat for searing and proper browning. Most foods are cooked at the “+” heat setting for the entire cooking time. However, when grilling large pieces of meat or poultry, it may be necessary to turn the heat to the lower setting after the initial browning. This cooks the food through without burning the outside. Foods cooked for a long time or foods basted with a sugary marinade may need the lower heat setting near the end of the cooking time.

NOTE: This grill is designed to grill efficiently without the use of lava rocks or briquettes of any kind. Heat is radiated by the stainless steel flame tamers positioned above each burner.

NOTE: The hot grill sears the food, sealing in the juices. The more thoroughly the grill is preheated, the faster the meat browns and the darker the grill marks.

**DO NOT LEAVE THE GRILL UNATTENDED WHILE COOKING.**

## Lighting Instructions

### **WARNING: IMPORTANT!** **BEFORE LIGHTING**

Inspect the gas supply hose prior to turning the gas “ON”. If there is evidence of cuts, wear, or abrasion, it must be replaced prior to use. Do not use the grill if the odor of gas is present. Only the pressure regulator and hose assembly supplied with the unit should be used.

Never substitute regulators and hose assembly for those supplied with the grill. If a replacement is necessary, contact the manufacturer for proper replacement. The replacement must be that specified in the manual.

**ALWAYS CHECK FOR LEAKS AFTER EVERY L.P. TANK CHANGE**

**Keep a spray bottle of soapy water near the gas supply valve and check the connections before each use.**

### **WARNING**

Always keep your face and body as far away from the burner as possible when lighting.

## TO LIGHT THE MAIN BURNER

Make sure all knobs are off then turn on the gas supply from the LP (Liquid Propane) tank. Always keep your face and body as far from the grill as possible when lighting.

To light your main burner, push and turn the main burner control knob to  , at the same time, press and hold electronic ignition button to light the burner. Once the burner is lit, release the electronic ignition button and knob. If the burner does not light wait 5 minutes for any excess gas to dissipate and then retry.

## Match Light

1. If the burner will not light after several attempts then the burner can be match lit, before using the match allow 5 minutes for any accumulated gas to dissipate.
2. Clip a match on one end of the lighting rod.
3. Light match.
4. Hold lighting rod and insert lighted match right next to the burner ports or ceramic tile.
5. Push and turn the designated control knob to .
6. Burner should ignite immediately.

Main burner

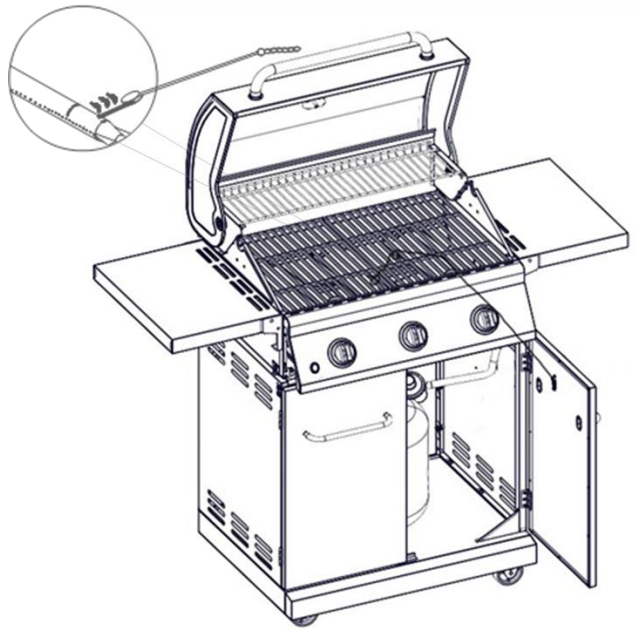

## Component Identification

**Note: Remove all packaging, including straps, before using the grill.**

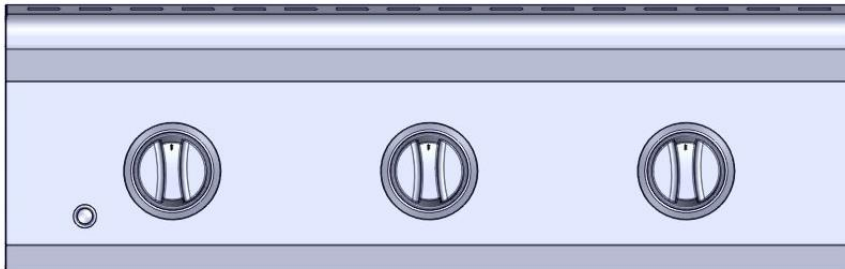

Main Burner

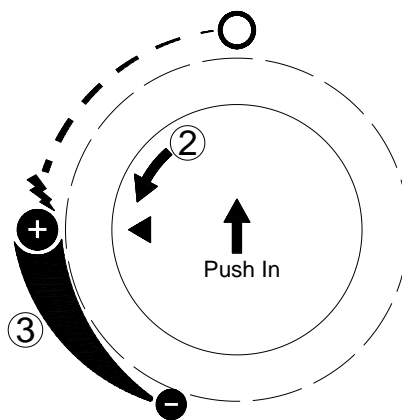

Control Knob, Label

## STAINLESS STEEL

There are many different stainless steel cleaners available. Always use the mildest cleaning procedure first, scrubbing in the direction of the grain. Do not use steel wool as it will scratch the surface. To touch up noticeable scratches in the stainless steel, sand very lightly with dry 100 grit emery paper in the direction of the grain. Specks of grease can gather on the surfaces of the stainless steel and bake on to the surface and give the appearance of rust. For removal use a mild abrasive pad in conjunction with a stainless steel cleaner.

## GRILL GRATE

The easiest way to clean the grill is immediately after cooking is completed and after turning off the flame. Wear a barbecue mitt to protect your hand from the heat and steam. Dip a brass bristle barbecue brush in water and scrub the hot grill. Dip the brush frequently in the bowl of water. Steam, created as water contacts the hot grill, assists the cleaning process by softening any food particles. If the grill is allowed to cool before cleaning, cleaning will be more difficult.

**ENSURE THAT THE GAS SUPPLY AND THE KNOBS ARE IN THE "O" POSITION. MAKE SURE THE RANGE TOP BURNER IS COOL BEFORE REMOVAL.**

## GRILL BURNERS

Extreme care should be taken when moving a burner as it must be correctly centered on the orifice before any attempt is made to relight the grill. Frequency of cleaning will depend on how often you use the grill.

## MAIN BURNER CLEANING

Ensure the gas supply is off and the knobs are in the "O" position. Make sure the grill is cool. Clean the exterior of the burner with a wire brush. Clear stubborn scale with a metal scraper. Clear any clogged ports with a straightened paper clip. Never use a wooden toothpick as it may break off and clog the port. Please note if insects or other obstructions are blocking the flow of gas through the burner, and if so you will need to call our customer service line 1- 866-984-7455 in USA and 1-800-648-5864 in Canada, language spoken: English, French, Spanish 8 a.m.-5 p.m., PST. Monday-Friday.

## GREASE TRAY CLEANING

The grease tray should be emptied and wiped down periodically and wash with a mild detergent and warm water solution. A small amount of sand may be placed in bottom of grease tray to absorb the grease. Check the grease tray frequently, do not allow excess grease to accumulate and overflow out of the grease tray.

**Warning: If you wish to replace main burner, we strongly recommend that you hire a professionally trained technician to replace it. Please understand that we will not be responsible for any liability, personal injury, or property damage resulting from an improperly assembled burner.**

## HOW TO REPLACE MAIN BURNER

**Step 1.** Remove the main burner "R" pin on the back wall of fire box by using needle nose pliers. Use a flathead screwdriver to remove burner pin cover, then remove the burner on the front wall of fire box, as shown below.

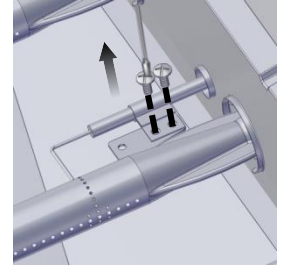
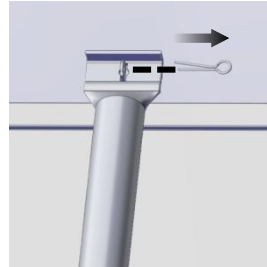

**Step 2.** Insert the burner onto the orifice and secure the burner pin cover on the burner, as shown below, make sure burner hole aim at orifice .

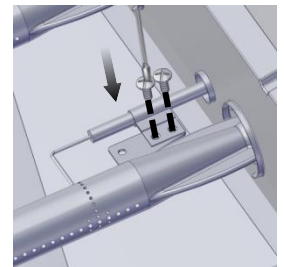
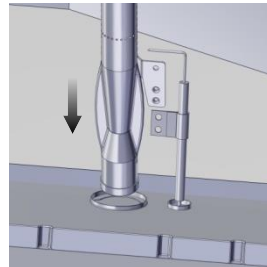

**Step 3.** Secure the main burner on the back wall of fire box with "R" Pin.

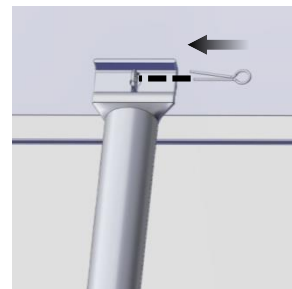

## CAUTION

1. Keep outdoor cooking gas appliance area clear and free from combustible materials, gasoline and other flammable vapors and liquids.
2. Do not obstruct the flow of combustible and ventilation air.
3. Keep the ventilation openings of the cylinder enclosure free and clear from debris.

## SPIDER AND INSECT WARNING

Checking and cleaning burner/ venturi tubes for insects and insect nests. A clogged tube can lead to a fire beneath the grill.

Although an obstructed burner tube is not the only cause of "FLASH-BACK", it is the most common cause.

To reduce the chance of "FLASH-BACK", you must clean the burner tubes before assembling your grill, and at least once a month in late summer or early fall when spiders are most active. Also perform this burner tube cleaning procedure if your grill has not been used for an extended period of time.

## WHEN TO LOOK FOR SPIDERS

You should inspect the burners at least once a year or immediately after any of the following conditions occur:

1. The smell of gas in conjunction with the burner flames appearing yellow.
2. The grill does not reach temperature.
3. The grill heats unevenly.
4. The burners make popping noises.

## BEFORE CALLING FOR SERVICE

If the grill does not function properly, use the following check list before contacting your dealer for service. You may save the cost of a service call.

**PREHEATING:** The grill lid should be in a closed position during the preheat time period. It is necessary to preheat the grill before cooking certain foods, depending on the type of food and the cooking temperature. Food that requires a high cooking temperature needs a pre-heat period of five minutes; food that requires a lower cooking temperature needs only a period of two to three minutes.

## COOKING TEMPERATURES

High setting-Use this setting for fast warm-up, for searing steaks and chops, and grilling.

Low setting-Use this setting for all roasting, baking, and when cooking very lean cuts such as fish.

These temperatures vary with the outside temperature and the amount of wind.

Cooking with in-direct Heat: You can cook poultry and large cuts of meat slowly to perfection on one side of the grill by indirect heat from the burner on the other side. Heat from the lit burner circulates gently throughout the grill, cooking the meat or poultry without any direct flame touching it. This method greatly reduces flare-ups when cooking extra fatty cuts, because there is no direct flame to light the fats and juices that drip down during cooking.

**CAUTION:** If burners go out during operation, close gas supply at source, and turn all gas valves off. Open lid and wait five minutes before attempting to relight (this allows accumulated gas fumes to clear).

**CAUTION:** Should a grease fire occur, close gas supply at source, turn off all burners and leave lid closed until fire is out.

**CAUTION:** DO NOT attempt to disconnect any gas fitting while your grill is in operation. As with all appliances, proper care and maintenance will keep them in top operating condition and prolong their life. Your gas grill is no exception.

**CAUTION:** Side burner lid will get hot if used when lid is closed.

PROBLEM	SOLUTION
When attempting to light my grill, it will not light immediately.	Make sure you have a spark while you are trying to light the burner (if no spark) . Check if the battery is installed properly. Ensure that the wire is connected to the electrode assembly. Clean wire (s) and / or electrode with rubbing alcohol and a clean swab. Wipe with a clean cloth. Check to see if the other burners operate. If so. Check the gas orifice on the malfunctioning burner for an obstruction.
Rotisserie burner will not light when the igniter button is pushed.	Check to see if debris is blocking the electrode. Check to see if there is a spark that jumps to the burner from the electrode. If no spark is seen, check the battery located inside the igniter box. To open turn counter Does the infrared back burner light when attempting to light with a match ? If not, check to ensure the gas is on.
Regulator makes noise.	Vent hose on the regulator may be plugged or regulator may be faulty. Ensure the vent hole on the regulator is not obstructed. Clear the hole, close the gas control valves. Wait ten minutes and re-start. Check your flames for proper performance. If the flames are not correct, replace regulator.
Full size cover does not fit the grill.	Cover may be incorrect for your grill. It may be a tight fit. Ensure the cover is the correct length for your grill. Measure it left to right. Compare to the grill's measurement. Compare the location and size of the hood portion of the cover to your grill. Spread the cover and allow it to relax, preferably in warm sunlight or in a warm room. For grill with a side shelf bunch the cover like a sock, put on left to right.

PROBLEM	SOLUTION
Rotisserie motor will not turn	Ensure the motor is connected to a properly grounded power supply. Ensure the on / off switch is in the on position. Ensure that the spit is fully inserted into the rotisserie motor. Ensure that the load does not exceed the 40 pounds operational capacity. Ensure that there is no encumbrance or drag.
Grill only heats to 93-149°C / 200-300°F.	Check to see if the fuel hose is bent or kinked. Make sure the grill area is clear of dust. Make sure the burner and orifices are clean. Check for spiders and insects. The regulator has a safety device that restricts the flow of gas in the event of a leak. This safety device can be triggered without a gas leak. To reset the safety device, turn off all burners and close the LP tank valve. Disconnect the regulator from the LP tank and wait one minute. Reconnect the regulator to the LP tank and slowly open the LP tank valve until the valve is fully open. Light all burners and observe the temperature.
Grill takes a long time to preheat.	Normal preheat 260-316°C / 500-600°F, takes about 10-15 min. Cold weather and wind may effect your preheat time. If you are using volcanic rock or briquettes they can increase the preheat time and maximum temperature.
Burner flames are not light blue.	Too much or not enough air for the flame. Elevation is the principal cause, however cold weather can affect the mixture. Burner adjustment may be required. Grill is in a windy location.

## Ordering Parts

### HOW TO ORDER REPLACEMENT PARTS

To make sure you obtain the correct replacement part (s) for your gas grill, please refer to the parts list on page 36. The following information is required to assure getting the correct part. Please note the shipping cost for the delivery of any replacement parts will be on yourself.

- Gas grills model number (see data sticker on grill).
- Part number of replacement part needed.
- Description of replacement part needed.
- Quantity of parts needed.

To obtain replacement parts, contact our customer service hotline, 1- 866-984-7455 in USA and 1-800-648-5864 in Canada, language spoken: English, French, Spanish 8 a.m.-5 p.m., PST. Monday-Friday.

### IMPORTANT

Use only factory authorized parts. The use of any part that is not factory authorized can be dangerous. This will also void your warranty.

Keep this assembly and operating instruction manual for convenient referral, and for replacement parts ordering.

## Grill Hints

The doneness of meat, whether rare, medium, or well done, is affected to a large degree by the thickness of the cut. Expert chefs say it is impossible to have a rare doneness with a thin cut of meat.

The cooking time is affected by the kind of meat, the size and shape of the cut, the temperature of the meat when cooking begins, and the degree of doneness desired.

When defrosting meats it is recommended that it be done overnight in the refrigerator as opposed to a microwave. This in general yields a juicier cut of meat.

Use a spatula instead of tongs or a fork to turn the meat, as a spatula will not puncture the meat and let the juices run out.

To get the juiciest meats, add seasoning or salt after the cooking is finished on each side and turn the meat only once (juices are lost when the meat is turned several times). Turn the meat just after the juices begin to bubble to the surface.

Trim any excess fat from the meat before cooking. To prevent steaks or chops from curling during cooking, slit the fat around the edges at 50.8 mm / 2-in. intervals.

**DO NOT LEAVE THE GRILL UNATTENDED WHILE COOKING.**

# Grill Cooking Chart

FOOD	WEIGHT OR THICKNESS	HEAT SETTING	APPROXIMATE TIME	SPECIAL INSTRUCTIONS AND TIPS
Vegetables				Slice. Dot with butter or margarine. Wrap in heavy -duty foil. Grill, turning occasionally.
Fresh Beets Carrots Turnips		Medium	12 to 20 minutes	Grill, turning once. Brush occasionally with melted butter or margarine.
Onion	1.3mm / 1/2 in. slices	Medium	8 to 20 minutes	Season with Italian dressing, butter, or margarine.
Potatoes Sweet White	Whole 170 to 226g / 6 to 8 oz	Medium High	40 to 60 minutes 45 to 60 minutes	Wrap individually in heavy - duty foil. Grill, rotating occasionally.
Frozen Asparagus Peas Green beans Sprouts		Medium	15 to 30 minutes	Dot with butter or margarine. Wrap in heavy -duty foil. Grill, turning occasionally.
French fries		Medium	15 to 30 minutes	Place in aluminum foil pan. Grill, stirring occasionally
Meats Beef Hamburgers	1-2 cm / 1/2 - 3/4 in.	Medium	10 to 18 minutes	Grill, turning once when juices rise to the surfaces. Do not leave hamburgers unattended since a flare-up could occur quickly. Cook to internal temperature of 160 degrees
Tenderloin		High	8 to 15 minutes	
Rare	2.5 cm / 1 in.	High	8 to 14 minutes	Trim edges. Grill, turning once
Medium	1.3 cm / 1/2 in. 2.5 cm / 1 in. 2.5 - 3.8 cm / 1-1/2 in.	High Medium to High	11 to 18 minutes 12 to 22 minutes 16 to 27 minutes	
Well - done	2.5 cm / 1 in. 2.5 - 3.8 cm / 1-1/2 in.	Medium Medium	18 to 30 minutes 16 to 35 minutes	
Lamb Chop & Steaks Rare	2.5 cm / 1 in. 2.5 - 3.8 cm / 1-1/2 in.	Medium to High	10 to 15 minutes 14 to 18 minutes	
Medium	2.5 cm / 1 in. 2.5 - 3.8 cm / 1-1/2 in.	Medium to High	13 to 20 minutes 18 to 25 minutes	Trim edges. Grill, turning once. Cook to desired doneness.
Pork Chops	2.5 cm / 1 in.	Medium	20 to 30 minutes	
Well -done	2.5 - 3.8 cm / 1-1/2 in.	Medium	30 to 40 minutes	

FOOD	WEIGHT OR THICKNESS	HEAT SETTING	APPROXIMATE TIME	SPECIAL INSTRUCTIONS AND TIPS
Ribs		Medium	30 to 40 minutes	Grill, turning occasionally. During last few minutes brush with barbecue sauce. Turn several times.
Ham steaks (precooked)	2.5 cm / 1 in. slices	High	4 to 8 minutes	Trim edges. Grill, turning once.
Hot dogs		Low	5 to 10 minutes	Slit skin. Grill, turning once.
Poultry	900 to 1400 g / 2 to 3 lb	Low or Medium	Up to 1 hour	Place skin side up. Grill, turning and brushing frequently with melted butter, margarine, oil or marinade.
Breasts well –done		Medium	30 to 45 minutes	Marinate as desired.
Fish and Seafood Halibut Salmon Swordfish	2 to 2.5 cm / 3/4 to 1 in.	Medium to High	8 to 15 minutes	Grill, turning once. Brush with melted butter, margarine or oil to keep moist.
Whole Catfish Rainbow trout	113 to 226 g / 4 to 8 oz	Medium to High	12 to 20 minutes	Grill, turning once. Brush with melted butter, margarine or oil. Brush with melted butter and lemon juice.

## BBQ SALMON

2 large salmon steaks  
2 tbs. Oil  
Salt & pepper  
2 oz. thin bacon slices  
2 tbs. Butter  
1 tbs. Lemon juice  
Spring of parsley  
Lemon wedges

Preheat the BBQ. Brush the steaks with oil and season with salt and pepper. Place on BBQ grill and cook for 10 minutes, turning steaks over halfway cooking time.

Meanwhile, fry the bacon in a pan on the side burner. Drain on paper towels. Melt the butter in a small saucepan taking care not to discolor it. Arrange the fish and bacon on serving plates. Pour the butter over and sprinkle with lemon juice. Garnish with parsley springs and lemon wedges. Serve with boiled potatoes tossed in butter and sprinkled with chopped parsley and a crisp lettuce salad.

Note: Substitute catfish, halibut or cod for salmon.

## BAKED CHILI CORN

6 medium ears corn, husked  
3 tbs. Butter or margarine, melted  
Dash ground cumin  
Dash ground coriander

About ½ hour before cooking, turn the butter on for grill. Place each corn on a heavy-duty foil. In a bowl, combine remaining ingredients. Mix well. Brush 1-1/2 tsp. Butter mixture over each ear. Close foil and fold up ends to seal. Place on grill. Cook, turning packets occasionally 10 to 12 minutes or until cooked through.

## TANGY SEAFOOD KABOBS

1 lb. Large shrimp, shelled & deveined  
¾ lbs. sea scallops  
2/3 c. chili sauce  
¼ c. cider vinegar

butter and sprinkled with chopped parsley and a crisp lettuce salad

In medium bowl, combine shrimp and scallops. In small bowl combine chili sauce and next six ingredients. Pour over seafood. Toss to coat. Cover, refrigerate 2 hours.

3 tbs. chopped parsley  
1 tbs. vegetable oil  
1 tbs. Worcestershire sauce  
½ tsp. prepared horseradish  
1 clove garlic, minced

1 20 oz. Can pineapple chunks in juice, drained half hour before cooking, turn the burner to the grill on full. Drain seafood reserving marinade. On each of twelve 10" skewers, thread 2 shrimps and 2 scallops, alternating with pineapple chunks. Place skewers on grill. Cook 7-10 minutes, often basting and turning.

## PORK CHOPS

4 Pork chops  
Marinade  
1 large onion  
2 tbs. lemon juice or vinegar  
2 tbs. oil  
½ tsp. powdered mustard  
2 tsp. Worcestershire sauce  
½ tsp. freshly ground black pepper  
1 tsp. sugar  
½ tsp. paprika  
1 clove garlic

Peel, grate onion, and add rest of the ingredients except the pork chops. Mix well. Pour over chops and marinate one hour in a cool place. Turn the BBQ grill on full. Heat 10 minutes.

BBQ the chops brushing with the marinade occasionally. Serve with mixed salad, dressed with vinaigrette flavored with fresh dill.

## BARBECUED LONDON BROIL

4 to 6 servings  
¾ c. Italian dressing  
1 tsp. Worcestershire sauce  
1 tsp. dry mustard  
¼ tsp. thyme, crushed  
1 medium onion, sliced  
1 pound flank steak, scored  
2 tbs. butter, melted

Combine first 4 ingredients, add onion and marinade flank steak with it. Refrigerate at least 4 hours or overnight. Remove steak and grill on your preheated BBQ grill. Grill 5 to 7 minutes on each side basting frequently with the marinade. In the meantime sauté onions from the marinade in butter in a skillet on your side burner for 3 minutes. To serve, slice steak diagonally into thin slices, sprinkle onions over top. Garnish with vegetable kabobs.

## BARBECUED POTATOES and CHEESE

1-1/2 cups shredded cheddar cheese  
1 can (10-3/4 oz.) condensed cream of mushroom soup  
1/3 cup milk  
2 tbs. barbecue sauce  
¼ tsp. oregano  
¼ tsp. salt

1/8 tsp. pepper  
4 cups thinly sliced potatoes (4 medium-sized potatoes)

Preheat grill. Combine cheese, condensed soup, milk, BBQ sauce, oregano, salt and pepper in a large mixing bowl. Stir in potatoes until well coated. Turn into well buttered 1-1/2 quart rectangular baking dish. Cover dish with aluminum foil. Bake covered 25 minutes on medium with the lid of your BBQ grill closed. Remove foil and continue baking 15 minutes longer or until potatoes are tender. Let stand 5 minutes before serving.

## VEGETABLE KABOBS

3 medium-sized zucchini  
12 cherry tomatoes  
12 fresh mushrooms  
Grated Parmesan cheese

Parboil whole zucchini 5 minutes on your side burner or until just tender. Drain and cut into ½ inch slices. Thread zucchini, tomatoes and mushrooms alternately on each of six skewers. Brush with marinade made of Italian dressing, Worcestershire sauce, mustard and thyme. Grill 5 to 7 minutes turning and basting occasionally. Sprinkle liberally with Parmesan cheese.

## FAJITAS

1-1/2 lb. flank steak or boned chicken breasts  
2 tbs. oil  
½ cup lime juice  
½ tsp. salt  
½ tsp. celery salt  
¼ tsp. garlic powder  
½ tsp. pepper  
¼ tsp. oregano  
¼ tsp. cumin  
Flour tortillas lemon

Pound flank steak to ¼ inch thickness or flatten chicken breasts. Mix oil, lime juice and seasonings in a zip lock bag. Add meat and shake bag to coat the meat. Refrigerate overnight or at least 6 to 8 hours. Wrap tortillas in foil. Remove meat from marinade. Cook on a preheated gas grill for 5 to 8 minutes on each side. While meat is cooking, heat tortillas on grill. Slice meat across grain in thin slices. Place on hot platter. Squeeze lemon juice over. Wrap meat and any of the following toppings in tortillas: chopped tomatoes, guacamole, sour cream, taco sauce.



## FAJITAS

1-1/2 lb. flank steak or boned chicken breasts  
2 tbs. oil  
½ cup lime juice  
½ tsp. salt  
½ tsp. celery salt  
¼ tsp. garlic powder  
½ tsp. pepper  
¼ tsp. oregano  
¼ tsp. cumin  
Flour tortillas lemon

Pound flank steak to ¼ inch thickness or flatten chicken breasts. Mix oil, lime juice and seasonings in a zip lock bag. Add meat and shake bag to coat the meat. Refrigerate overnight or at least 6 to 8 hours. Wrap tortillas in foil. Remove meat from marinade. Cook on a preheated gas grill for 5 to 8 minutes on each side. While meat is cooking, heat tortillas on grill. Slice meat across grain in thin slices. Place on hot platter. Squeeze lemon juice over. Wrap meat and any of the following toppings in tortillas: chopped tomatoes, guacamole, sour cream, taco sauce.

## BEEF AND LAMB KABOBS

Serve 4

½ lb. boneless sirloin or beef cut into 1" cubes  
½ lb. boneless loin of lamb cut into 1" cubes  
2/3 c. water, divided  
¼ c. chopped onion  
2 tbs. soy sauce  
¼ c. vegetable oil, divided  
1 tbs. dark brown sugar  
1 tbs. fresh lemon juice  
2 cloves garlic, minced  
¼ tsp. ground cumin  
¼ tsp. ground coriander  
¼ tsp. ground turmeric  
1/8 tsp. ground red pepper  
1/8 tsp. ground ginger  
1 red pepper cut into chunks  
1 large banana, cut into chunks  
8 small mushrooms  
1/3 c. smooth peanut butter

About ½ hour before cooking, turn the butter on for grill. Place each corn on a heavy-duty foil. In a bowl, combine remaining ingredients. Mix well. Brush 1-1/2 tsp. Butter mixture over each ear. Close foil and fold up ends to seal. Place on grill. Cook, turning packets occasionally 10 to 12 minutes or until cooked through. Bring marinade to boil on the side burner in a saucepan. Add remaining 1/3 c. water and peanut butter. Stir to blend. Heat through. If sauce gets too thick, add 1 tbs. water. Serve sauce with kabobs.

## EGGPLANT CAVIAR

1 large eggplant  
2 tbs. olive oil  
2 tbs. wine vinegar  
2 tbs. finely chopped onion  
½ clove garlic, minced  
1 medium tomato, chopped salt and pepper

Roast eggplant on gas grill over medium flame, turning occasionally until thoroughly cooked. This may take 30 minutes. Remove from grill and cool for handling. Strip off the skin and chop eggplant finely. Add all the seasonings. Chill thoroughly and serve on toast.

## CHICKEN TANDOORI STYLE

8 large chicken thighs or drumsticks  
1 c. plain nonfat yogurt  
½ c. lemon juice  
2 tsp. salt  
½ tsp. cayenne  
½ tsp. black pepper  
½ tsp. crushed garlic  
½ tsp. grated ginger  
1 tbs. corn oil

Combine all the ingredients in a large mixing bowl and marinate the chicken for 8 hours in the refrigerator. Drain the chicken and spread on the spit running the rod on the fleshier side of the bone. Roast using the rotisserie burner. Cook on medium high heat for 40 minutes basting occasionally with the remainder of the marinade mixture. Serve with sliced onions and lemon wedges.

## SPARE RIBS

Marinade:

1 c. soy sauce  
½ c. honey  
½ c. vinegar  
½ c. dry sherry  
2 tsp. chopped garlic  
2 tsp. sugar  
1 c. water  
1 chicken bouillon cube  
1 can beer for basting sauce

Marinate ribs for 3 hours. Use marinade for basting by adding beer to it. Place pan under the ribs and baste frequently. To cook ribs select lean, meaty ribs and accordion pleat them with your spit. Slide four prong meat hook down the length of spit and tighten. At the beginning of the rack and to its center, penetrate the second rib with the pointed end of the spit and push it between the meat. Skip a couple and continue the process until the entire rack is accordion pleated. Fasten the second meat hook into the rack. Turn your rotisserie burner on high. Roast for 50 minutes or until done.

## PORK ROAST

Apple cider vinegar basting sauce:  
1 c. apple cider vinegar  
6 oz. water  
½ stick butter  
Salt, pepper, parsley and garlic seasoning  
2 oz. lemon juice  
10 lbs. pork roast

Time: 1-1/2 hours to 2 hours

Bring pork to room temperature before placing it on the spit rod. Place on the rod and test for balance. Light rotisserie burner. Turn control knob to high. Use the above basting sauce for rotissing.

## TURKEY

12 lb. turkey  
Beer basting sauce:  
1 can beer  
12 oz. water  
1 stick butter  
1 tsp. salt  
1 tsp. pepper  
½ tsp. garlic flakes  
1 tsp. parsley

Thaw the bird completely. Wash inside out. Securely tie the legs and wings. Light rotisserie burner. Turn to high. Combine all the ingredients for basting sauce in a shallow pan. Place it under the turkey 15 to 20 minutes. Cook for approximately 3 hours. The basting sauce combined with turkey drippings makes a delicious gravy.

# LIMITED WARRANTY

The manufacturer warrants to the original consumer-purchaser only that this product (*Model #720/730-0830MH*) shall be free from defects in workmanship and materials after correct assembly and under normal and reasonable home use for the periods indicated below beginning on the date of purchase. The manufacturer reserves the right to require photographic evidence of damage, or that defective parts be returned, postage and/or freight pre-paid by the consumer, for review and examination. Nexgrill's obligation is limited to repair, replacement, or depreciated value, at the option of Nexgrill.

- **TUBE BURNERS:** 10 year *LIMITED* warranty against perforation.
- **COOKING GRIDS and FLAME TAMERS:** 1 year *LIMITED* warranty; *does not cover dropping, chipping, scratching, or surface damage.*
- **STAINLESS STEEL PARTS:** 1 year *LIMITED* warranty against perforation; *does not cover cosmetic issues like surface corrosion, scratches and rust.*
- **ALL OTHER PARTS:** 1 year *LIMITED* warranty (Includes, but not limited to, valves, frame, housing, cart, control panel, igniter, regulator, hoses) *\*Does not cover chipping, scratching, cracking surface corrosion, scratches or rust.*

Upon consumer supplying proof of purchase as provided herein, Manufacturer will repair or replace the parts which are proven defective during the applicable warranty period. Parts required to complete such repair or replacement shall be free of charge to you ~~except~~ for shipping costs, as long as the purchaser is within the warranty period from the original date of purchase. The original consumer-purchaser will be responsible for all shipping charges of parts replaced under the terms of this limited warranty. This limited warranty is applicable in the United States and Canada only, is only available to the original owner of the product and is *not transferable*. Manufacturer requires reasonable proof of your date of purchase. Therefore, you should retain your sales receipt and/or invoice. If the unit was received as a gift, please ask the gift-giver to send in the receipt on your behalf, to the below address. Defective or missing parts subject to this limited warranty will not be replaced without registration or proof of purchase. This limited warranty applies to the functionality of the product **ONLY** and does not cover cosmetic issues such as scratches, dents, corruptions or discoloring by heat, abrasive and chemical cleaners or any tools used in the assembly or installation of the appliance, surface rust, or the discoloration of stainless steel surfaces. Surface rust, corrosion, or powder paint chipping on metal parts that does not affect the structural integrity of the product is not considered a defect in workmanship or material and is not covered by this warranty. This limited warranty will not reimburse you for the cost of any inconvenience, food, personal injury or property damage. If an original replacement part is not available, a comparable replacement part will be sent. You will be responsible for all shipping charges of parts replaced under the terms of this limited warranty.

#### MANUFACTURER WILL NOT PAY FOR:

- Service calls to your home.
- Repairs when your product is used for other than normal, single-family household or residential use.
- Damage resulting from accident, alteration, misuse, lack of maintenance/cleaning, abuse, fire, flood, acts of God, improper installation, and installation not in accordance with electrical or plumbing codes or misuse of product.
- Any food loss due to product failures.
- Replacement parts or repair labor costs for units operated outside the United States or Canada.
- Pickup and delivery of your product.
- Postage fees or photo processing fees for photos sent in as documentation.
- Repairs to parts or systems resulting from unauthorized modifications made to the product.
- The removal and/or reinstallation of your product.
- Shipping cost, standard or expedited, for warranty/non warranty and replacement parts.

#### DISCLAIMER OF IMPLIED WARRANTIES; LIMITATION OF REMEDIES

*Repair or replacement of defective parts is your exclusive remedy* under the terms of this limited warranty. Manufacturer will not be responsible for any consequential or incidental damages arising from the breach of either this limited warranty or any applicable implied warranty, or for failure or damage resulting from acts of God, improper care and maintenance, grease fire, accident, alteration, replacement of parts by anyone other than manufacturer, misuse, transportation, commercial use, abuse, hostile environments (inclement weather, acts of nature, animal tampering), improper installation or installation not in accordance with local codes or printed manufacturer instructions.

THIS LIMITED WARRANTY IS THE SOLE EXPRESS WARRANTY GIVEN BY THE MANUFACTURER. NO PRODUCT PERFORMANCE SPECIFICATION OR DESCRIPTION WHEREVER APPEARING IS WARRANTED BY MANUFACTURER EXCEPT TO THE EXTENT SET FORTH IN THIS LIMITED WARRANTY. ANY IMPLIED WARRANTY PROTECTION ARISING UNDER THE LAWS OF ANY STATE, INCLUDING IMPLIED WARRANTY OF MERCHANTABILITY OR FITNESS FOR A PARTICULAR PURPOSE OR USE, IS HEREBY LIMITED IN DURATION TO THE DURATION OF THIS LIMITED WARRANTY.

Neither dealers nor the retail establishment selling this product has any authority to make any additional warranties or to promise remedies in addition to or inconsistent with those stated above. Manufacturer's maximum liability, in any event, shall not exceed the documented purchase price of the product paid by the original consumer. This warranty only applies to units purchased from an authorized retailer and/or re-seller.

NOTE: Some states do not allow an exclusion or limitation of incidental or consequential damages, so some of the above limitations or exclusions may not apply to you; this limited warranty gives you specific legal rights as set for herein. You may also have other rights which vary from state to state.

If you wish to obtain performance of any obligation under this limited warranty, you should write to:

**Nexgrill Customer Relations**  
**14050 Laurelwood Pl**  
**Chino, CA 91710**

*All consumer returns, parts orders, general questions, and troubleshooting assistance can be acquired by calling 1-866-984-7455 in USA and 1-800-648-5864 in Canada, language spoken: English, French, Spanish 8 a.m. -5 p.m., PST. Monday-Friday.*

安全說明.....	18	故障排除.....	27
安裝瓦斯.....	22	訂購零件.....	28
安裝者最終檢核表.....	23	烤爐烹飪對照表.....	29
洩漏測試.....	23	建議食譜.....	31
操作說明.....	24	有限保固.....	33
烤爐點火說明.....	24	展開視圖.....	34
保養及維護.....	26	零件清單.....	36

## 安全說明

## ⚠ 危險

如果聞到瓦斯異味：

- 關掉裝置的瓦斯開關。
- 撲滅任何明火。
- 打開烤爐蓋板。
- 若還是聞得到瓦斯異味，請遠離烤爐並馬上聯絡瓦斯供應商或消防局。

## ⚠ 警告

1. 不要在本裝置或其他裝置附近儲存或使用汽油或其他可燃液體或氣體。
2. 不要把未使用的液態瓦斯桶放在本裝置或其他裝置附近。

## ⚠ 危險

1. 使用本裝置時需隨時有人看顧。
2. 操作本裝置時，切勿於3公尺（10英尺）的距離內接觸任何結構物、可燃材料或其他的瓦斯桶。
3. 操作本裝置時，切勿於7.5公尺（25英尺）的距離內有任何可燃液體。
4. 不要超過烹飪容器的最大容量的指示標線。
5. 在烹調過程後，熱的液體仍會於較長的時間內保持炙熱的高溫。切勿觸摸烹調裝置，除非液體已降至45° C（115° F）或更低的溫度。
6. 本裝置並不適用於，並且絕不能做為加熱器使用。
7. 若發生火災，請遠離本裝置並立即呼叫消防局。切勿嘗試以水撲滅油火。

⚠ 未確實遵守這些說明可能導致火災或爆炸，造成人員嚴重的身體傷害、死亡或財物毀損。

⚠ 烤爐裝會變得很燙。使用時千萬不要靠在烹煮區域。不要碰觸使用中的烤爐的烹煮區表面、烤爐外殼、蓋板或是其他的烤爐零件。

⚠ 危險

在未閱讀本手冊「點火說明」的段落之前，切勿點燃本裝置

已根據CNS 13604（家庭用燃氣炊煮器具）進行了測試。

正確使用LP儲氣罐

LP燃氣燒烤架型號設計用於標準9 kg / 20lb。燒烤架不包括液體丙烷儲氣罐。切勿將燃氣燒烤爐連接到超過此容量的低壓燃氣罐。

注意：

瓦斯正常流動經過調節器及軟管組件時會產生嗡嗡的雜音。少量的雜音是很正常的並不會影響烤爐的操作。若雜音過大且過度，可能需要清除瓦斯管線中的氣體或是重新安裝調節器的瓦斯過量裝置。清除氣體的程序需在每次烤爐安裝新的瓦斯桶時進行。

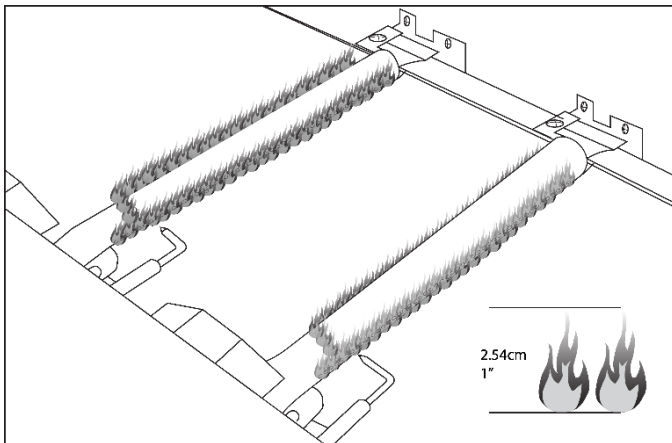

每次使用前以目視檢查燃燒器火焰。火焰看起來應如以上圖示。若外觀並非如圖中所示，請參考本手冊的燃燒器維護段落。

小心：注意逆燃

小心：蜘蛛和小昆蟲在運送及倉儲期間可能會在燒烤爐的燃燒器管內結網或築巢。結網會導致瓦斯流動受阻並造成燃燒器管周圍燃燒起火。這類的起火源即所謂的「逆燃」，它會導致烤爐嚴重的毀損並形成一個對使用者不安全的操作環境。



雖然燃燒器管受阻並非造成「逆燃」的唯一因素，但它是最常造成「逆燃」的主因。

要降低「逆燃」的發生機率，必須在組裝之前先清理燃燒器管，並且於夏末秋初蜘蛛活動最頻繁的季節，每月至少清理一次。若烤爐已經有一段時間未使用，也應依未使用過的程序清理燃燒器管。管路阻塞會導致烤爐下方起火。

## 瓦斯供給系統

- 若未確實遵守所提供的資訊，可能會發生火災而導致死亡或嚴重的傷害。
- 最大可使用9分斤（20磅）的瓦斯桶，尺寸約為：直徑32.0公分（12英寸）、高度45.6公分（18.5英寸）。
- 瓦斯桶的出口閥必須配有一個停止閥終端，可與類型1的瓦斯桶搭配使用。瓦斯供給鋼瓶出口閥必須配有一個停止閥終端專為連接類型POL。瓦斯供給鋼瓶需安裝過充保護裝置（O.P.D.）。而瓦斯桶也必需安裝直接連接揮發氣空間的安全洩壓裝置。此安全特性可預防瓦斯桶填充過量，而造成瓦斯桶、調節器以及 / 或是烤爐的故障。
- 瓦斯桶供給系統必須具有揮發氣回收的設計安排。
- 使用的瓦斯桶必須要安裝護圈，以保護閥門。
- 不使用瓦斯桶時須在瓦斯桶出口閥上方加裝防塵蓋。瓦斯桶出口閥只能安裝與鋼瓶閥門一同附上的防塵蓋。其他種類的蓋子或栓塞可能會造成丙烷氣洩露。
- 烤爐切勿與未受規範的瓦斯桶連結。
- 本瓦斯戶外用烹飪裝置配有高容量軟管 / 調節器組套件，做為與標準的9公斤（20磅）容量的瓦斯桶連接使用。
- 瓦斯桶應該交由具聲譽的丙烷氣經銷商填充，而在每次填充後以目視檢查並重新檢測取得合格資格。
- 切勿將額外的瓦斯桶放置於本裝置的下方或靠近它的區域。
- 瓦斯桶的填充量不可超過八分滿。
- 瓦斯桶必須隨時直立放置。
- 切勿存放汽油或是其他可燃的揮發氣或液體於本產品或任何其他裝置附近。
- 唯有在瓦斯桶拆卸下來並將其由瓦斯戶外用烹飪裝置上移除後，才可將瓦斯戶外用烹飪裝置貯存於室內。
- 當烤爐並未使用瓦斯時，必需關閉瓦斯桶開關。烤爐正確的擺放位置與清理。

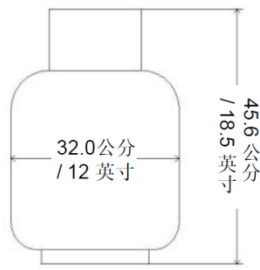

## 烤爐正確的擺放位置與間隙

- 瓦斯烤爐僅限於戶外使用，切勿於車庫、前廊、棚架、穿堂或是其他封閉的區域使用。本產品切勿安裝於可燃的圍地內，與可燃的結構物兩側及後方最少應保持91公分（36英寸）的淨空距離。

- 切勿在架空的可燃物表面下方使用本裝置。本瓦斯戶外用烹飪裝置並非設計於露營車輛以及 / 或是船隻上使用。
- 烹飪瓦斯裝置不使用時必需關閉瓦斯桶的開關。
- 瓦斯桶必須貯存於通風良好且孩童接觸不到的區域。拆卸下來的瓦斯桶不可存放在建築物、車庫或是其他任何的封閉場所。
- 烤爐外殼四周的通風不可受阻。僅能使用烤爐所附的調節器及軟管組套件。更換調節器及軟管組套件時只能使用本手冊所指定的規格。
- 每次使用烤爐前必需檢查調節器及軟管組套件。若有過度的磨損、耗損或是軟管遭切割受損，則必須在使用烤爐前進行更換。軟管組套件應使用製造商所指定的規格。
- 必需使用瓦斯戶外用烹飪裝置所附的壓力調節器及軟管組套件。切勿置換其他類型的調節器。請與客服部門聯絡詢問製造商所指定的替換零件。
- 不論是何種烤爐皆不可使用煤磚。
- 烤爐設計為可在不使用煤磚時可達到最佳的使用狀態。不可將煤磚放在熱輻射的區域，因會阻斷烤爐的通風孔。加入煤磚會損壞點火裝置的零件及旋鈕，而這將會使保固失效。
- 後方及兩側的車架不可有垃圾碎屑。所有的電源連接線或是回轉式烤肉架馬達電線需遠離烤爐熱源區域。
- 切勿在強風的狀況下使用烤爐。若位於風大的區域（沿海地帶、山頂等處）需要準備擋風設備。必須隨時保持指定的間隔距離。
- 千萬不可使用凹陷、生鏽的瓦斯桶。
- 任何的電源線及燃料供應管線必須遠離熱的表面。
- 點火時，臉與手請儘量遠離烤爐。
- 只能在燃燒器冷卻後才能調整燃燒器。

### 警告

烤爐會變得很燙。在使用烤爐時千萬不要靠在烹調區域。烤爐在運轉或是烤爐使用後直到冷卻的這段時間，不要碰觸烹煮表面、烤爐外殼、蓋板或是烤爐的其他任何零件。未確實遵照這些指示說明，會導致身體嚴重的傷害。

### 小心：

為確保能持續的保護以避免觸電的風險，插頭僅能確實地與接地電源相接。為降低觸電的風險，延長線接頭需保持乾燥並離地。

 **警告**

將內裝肥皂水的噴霧罐放在靠近瓦斯供給閥的地方，並在每次使用前檢查接點。

 **警告**

本瓦斯戶外用烹飪裝置並非設計於露營車輛以及 / 或是船隻上使用。

**勿將鋁箔紙排列擺放在烤架上或是烤爐底。**

**這會嚴重地阻礙到控制區域的燃燒氣流或是會讓過高的熱度無法排除。**

### 避免人身傷害的安全措施

雖然正確地保養可以提供烤爐長年安全、可靠的使用。然而，在烤爐產生高熱時會增加意外事故潛在性，需格外留意。在使用本裝置時，包含以下所列的基本安全操作事項必須加以遵守：

不可維修或更換烤爐的任何零件，除非本手冊有特別明確的建議。其他的維修服務應請教合格的技術人員。  
本烤爐並非設計安裝或放置於露營車輛或是船隻上。

在使用烤爐時的周遭區域不可獨留孩童或是任其無人看顧。無論何時都不能允許孩童在烤爐上或是周圍坐著、站立或是遊戲。不要存放會使孩童感到興趣的物品於烤爐周圍或是其下方。

切勿允許衣物、隔熱手套或是其他可燃材質在烤爐還未冷卻前與任何烤架、燃燒器或是熱的表面接觸或是過於靠近。布料可能會點燃並造成人身傷害。

為了人身安全，請穿戴合適的服裝。寬鬆的衣著或袖子千萬不可在使用本裝置時穿戴。部分合成纖維織物極其易燃，不應於烹飪時穿戴。

只有部分種類的玻璃、耐熱玻璃陶瓷，陶器或是其他釉面器皿才適合用於烤爐。這些材質會因溫度驟變而破裂，請依製造商的指示以低溫或是中度溫度設定使用。

不要將未拆封的食物容器加熱。加熱累積的壓力會造成容器破裂。

打開烤爐上蓋時要戴手套。不要倚靠在烤爐上。

在點燃燃燒器時，需專注於自己所進行的動作。確認您所要點燃的是那一個燃燒器，這樣才能使身體及衣物與點燃的火源保持一定的距離。

烤爐在使用時，切勿觸摸烤爐架、燃燒器格柵或是緊鄰烤爐周圍的區域，因這些區域會變得很燙，而造成灼傷。只能使用乾燥的隔熱墊。潮溼的隔熱墊與熱表面接觸後可能會導致蒸氣灼傷。不要以毛巾或是粗重布料置於該處或是做為隔熱墊。不得將隔熱墊接觸烤架灼熱的部位。

油脂具可燃性。熱的油脂待冷卻後再進行清理。切勿讓油脂堆積於烤爐火箱底部的集油盤內。須經常清理集油盤。

勿將鋁箔紙排列擺放在烤架上或是烤爐底。這會嚴重地阻礙到控制區域的燃燒氣流或是會讓過高的熱度無法排除。為使烤爐能準確的點火及操作，燃燒器端口需保持乾淨。必須定時地清潔以便達到最佳的使用狀態。燃燒器只能固定一個位置使用並且必須正確架設以便能安全的進行操作。

清理烤爐時須小心。為免被蒸氣燙傷，在烤爐仍灼熱時不要使用溼海綿或是布料清理。部分清潔用品會在塗於熱的表現時散發出有毒氣體或是被引燃。

在使用任何種類的噴霧清潔劑於烤爐及其周圍之前，先關閉烤爐控制開關並確認烤爐已冷卻。製造噴露的化學劑在有熱源的狀況時，會被點燃或是造成金屬零件侵蝕的狀況。

不要使用烤爐烹煮油脂豐厚的肉品，或是其他會造成突發火焰的食品。

切勿在未受保護的可燃結構物下方操作烤爐。僅能於通風良好處使用本產品。切勿於建築物內、車庫、棚架、穿堂或是其他封閉的區域使用。

烤爐四周圍需遠離可燃材料，包括液體、落葉以及諸如汽油或木炭液體燃料的揮發氣。切勿阻礙燃燒及通風氣流的流通。

。本裝置切勿安裝不合規範的瓦斯供給管線。

使用產品所提供的調節器 / 軟管組套件。

本烤爐需安裝液化丙烷裝置。除非烤爐經重新裝配，否則不可與天然瓦斯供給管線連接使用。本不鏽鋼瓦斯烤爐在所有燃燒器設定在的情況下，總瓦斯消耗量（每小時）分別為：

主烤爐	3 X 4 kW/hr.
總計	12 kW/hr.

## 瓦斯桶要求

凹陷、生鏽的瓦斯桶有發生危險之虞，應由瓦斯供應商檢查。切勿使用閥門已損壞的瓦斯桶。瓦斯桶供給系統必須具有揮發氣回收的設計安排。使用的瓦斯桶必須要安裝護圈，以保護閥門。

歧管壓力：2.8 kPa。

## 安裝瓦斯

確認瓦斯桶閥門上的黑色塑膠絕緣環已安裝就位，而軟管並未與集油盤或是烤爐前端相接。

## 連接

不鏽鋼烤爐配備瓦斯供應噴嘴，僅限輸送液化丙烷氣。產品同時配有高容量軟管 / 調節器組套件，做為與標準的9公斤（20磅）容量的瓦斯桶（高45.6公分（18.5英寸）、直徑32.0公分（12英寸））連接使用。

所有更換的調節器應使用出口壓力為2.8 kPa 壓力。

與瓦斯桶連接時，請遵照以下步驟：

1. 確認瓦斯桶的閥門完全鎖緊關閉（順時針轉到底）。
2. 檢查以確認瓦斯桶的閥門為正確可外接的外螺紋。

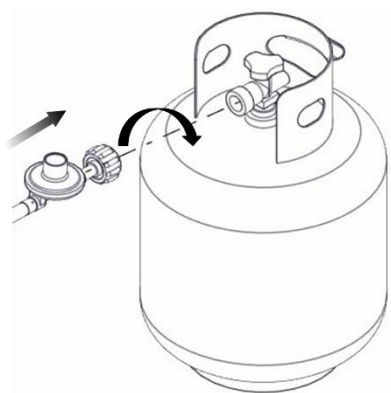

3. 確認所有燃燒器的閥門皆已關閉。
4. 檢查閥門接點、端口及調節器的組套件。查看是否有損壞或是碎屑。將碎屑取出。檢查軟管是否損傷。切勿試圖使用受損或是堵塞的設備。與當地的瓦斯經銷商聯絡維修事宜。
5. 調節器組套件與閥門連接時，以手將快速接頭螺帽依順時針方向鎖到底。不要以扳手鎖緊。使用扳手會使快速接頭螺帽受損，並會產生危險的狀況。
6. 將瓦斯桶閥門完全打開（逆時針方向）。以乾淨的刷子將肥皂水塗於接點位置。請參考下圖。若有氣泡產生則表示接頭並未完全的鎖緊。檢查每一個裝置配件並加以鎖緊，或是視情況需要進行維修。
7. 若瓦斯接點洩漏無法維修，請將瓦斯桶關閉並拆下烤爐的燃料管線。而有關於零件的更換，可與我們的客服部門聯絡。美國當地請撥：1- 866-984-7455而加拿大當地請撥：1-800-648-5864；我們提供英語、西語、法語的服務。來電請於太平洋標準時間，禮拜一至禮拜五上午8點至下午5點。
8. 將肥皂溶液塗在瓦斯桶的接縫處。請參考下圖。若出現氣泡，關閉瓦斯桶開關並不得使用或移動它。與瓦斯供應商或是消防局聯絡尋求協助。

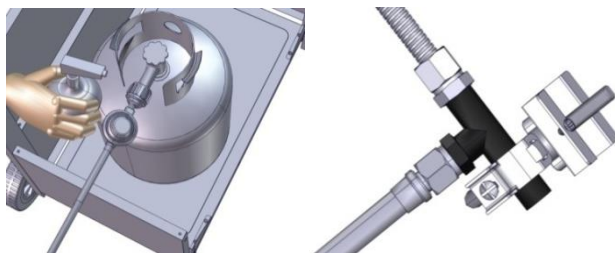

## 拆裝瓦斯桶：

1. 關閉燃燒器開關。
2. 將瓦斯桶的閥門開關完全關閉（順時針轉到底）。
3. 以逆時針方向轉動快速接頭螺帽，將調節器組套件由瓦斯桶的閥門處拆下。

- ✓ 與可燃的結構物兩側及後方最少應保持**91公分（36英寸）**的間隙。
- ✓ 所有的內包裝都已拆封移除。
- ✓ 旋鈕可轉動自如。
- ✓ 燃燒器固定並適當地安置於噴嘴上。
- ✓ 壓力調節器已連接並安裝完成。以產品所提供的軟管與調節器組套件（已預設**2.8 kPa（11英寸水柱）**）將瓦斯與烤爐連接。
- ✓ 裝置經測試並無洩漏。
- ✓ 使用者已被告知瓦斯供給關閉閥的位置。

使用者請保留此手冊以供日後使用。瓦斯桶注意事項

- a) 切勿將額外的瓦斯桶放置於本裝置的下方或靠近它的區域。
- b) 瓦斯桶的填充量不可超過八分滿。
- c) 若未確實遵照以上「a」、「b」項的說明，可能會引起造成死亡或是嚴重傷害的火災或是爆炸發生。

## 洩漏測試

### 一般事項

雖然烤爐上的所有瓦斯接點都已在出貨前於工廠做過洩漏測試，但由於在運送過程中可能的不當處理，或是在無察覺的狀況下累積於裝置的高壓，因此必須在安裝時進行完整的氣密性檢查。定期地依以下所列步驟為整體系統進行洩漏測試。若於任何時候聞到瓦斯氣味，應立即進行整體系統的洩漏測試。

### 進行測試前

確認包括束帶的所有包材皆已自烤爐上移除。

在進行洩漏測試時切勿吸煙。

千萬不能以明火進行洩漏測試。

以部分的清潔劑和水混合製成肥皂水。需要用到噴霧罐、刷子或是抹布將溶劑塗抹於裝置配件上。進行最初的洩漏測試時，確認瓦斯桶為八分滿。

### 進行測試

1. 確認控制閥位於「○」位置時，並開啟瓦斯供應。
2. 檢查由瓦斯調節器一直到供應閥的所有接點，並包括歧管組合件的接點（連接至燃燒器的管線）。肥皂泡將顯示出瓦斯洩漏的地方。
3. 若有洩漏的狀況，請立即關閉瓦斯供應並將洩漏的裝置配件鎖緊。
4. 再開啟瓦斯並重新做檢查。
5. 若裝置配件持續有瓦斯洩漏，請關閉瓦斯供給並與我們的客服部門聯絡。美國當地請撥：**1-866-984-7455**而加拿大當地請撥：**1-800-648-5864**；我們提供英語、西語、法語的服務。來電請於太平洋標準時間，禮拜一至禮拜五上午8點至下午5點。

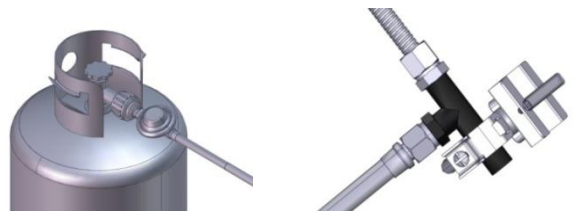

唯有製造商建議的零件才可使用於烤爐。使用代用品將會使保固失效。直到所有接點都經檢查且未產生洩漏後才可使用烤爐。

### 氣流檢測

所有烤爐的燃燒器在出貨前已於工廠經測試與調整；然而，因當地的瓦斯供應各有所不同，可能會需要調整燃燒器。應以目視檢查燃燒器的火焰。火焰應為藍色且呈穩定且頂端無黃色火焰、過大的噪音或是上飄火焰。若有任何此類的狀況發生，檢查氣窗或是燃燒器端口是否因灰塵、碎屑、蜘蛛網等物而受阻塞。若有任何有關於火焰穩定性的問題，請與我們的客服部門聯絡，美國當地請撥：**1-866-984-7455**，加拿大當地請撥：**1-800-648-5864**，我們提供英語、西語、法語的服務。來電請於太平洋標準時間，禮拜一至禮拜五上午8點至下午5點。

每次更換瓦斯桶後都需做洩漏測試

在每次使用之前，檢查所有瓦斯供應的裝置配件是否有瓦斯洩漏。將內裝肥皂水的噴霧罐放在靠近瓦斯供給管線停止閥以便於使用。將肥皂水噴灑於裝置配件。若有氣泡產生則表示有洩漏。



## 烤爐與回轉式烤肉架的一般使用

每一個燃燒器的額定值為 4.00 kW/小時。主燃燒器涵蓋全部的烹煮區域，並有側通道能使掉落的油脂及碎屑所造成阻塞的狀況減至最小。點火旋鈕位於閥門控制面板的底部中央部位。每一個旋轉點火器在控制面板處皆有標籤標示。

## 使用烤爐

火烤時需要使用高溫以便燒烤及適當的為食物上色。大部分的食物在烹煮時全程皆設定以「+」烹煮。然而，在火烤大塊肉類或是家禽肉品時，可能需要在初步的食物上色階段之後，將熱度設定至較低溫。這樣的烹煮方式可將食物煮熟而不會使表層烤焦。在長時間烹煮食物或是食物塗含糖醃料時，需要在接近烹調完成之前將溫度設定成較低溫度。

**注意：**烤爐設計為可在不使用火山石或任何種類的煤磚時有效率的燒烤食物。熱能是經由每一個燃燒器上方設置的不鏽鋼火焰控制器所放射出的。

**注意：**熱燙的烤爐可燒烤食物、鎖住食物原汁。烤爐預熱的越徹底肉品上色的速度越快，而烤架燒灼痕的顏色會更深。

烹煮食物時切勿離開烤爐。

## 烤爐點火說明

### 警告：重要事項！

### 點火之前

在瓦斯「開啟」之前先檢查瓦斯供給軟管。若有切割、損耗或是磨損的狀況，必須先做更換才可使用。若有瓦斯氣味則請勿使用烤爐。僅可使用隨貨附上的壓力調節器與軟管組合作件。切勿置換烤爐所配備的調節器以及軟管組合作件。若必須更換，請與製造商聯絡以獲得正確的替換品。替換品必須與手冊指定的規格相同。

每次更換瓦斯桶後都需做洩漏測試

在每次使用之前，檢查所有瓦斯供應的裝置配件是否有瓦斯洩漏。將內裝肥皂水的噴霧罐放在靠近瓦斯供給管線停止閥以便於使用。將肥皂水噴灑於裝置配件。若有氣泡產生則表示有洩漏。

### 警告

點火時，隨時將臉與身體儘量遠離燃燒器。

### 點燃主燃燒器

雖然烤爐上的所有瓦斯接點都已在出貨前於工廠做過洩漏測試，但由於在運送過程中可能系統的洩漏測試。點燃主燃燒器時，壓下並轉動主燃燒器控制旋鈕至「」，同時壓下電子點火按鈕並保持不動以點燃燃燒器。一旦燃燒器被點燃，放開電子點火按鈕以及旋鈕。若無法點燃，再等5分鐘讓溢出的瓦斯氣消散後再重新試一次。

## 以火柴點燃燒烤燃燒器

1. 若先前試圖以點火器將燃燒器點燃，先等5分鐘讓累積的瓦斯氣消散。點火時，臉與手請儘量遠離烤爐。
2. 將點燃的火柴裝入點火棒穿過烤架靠近燃燒器。
3. 點燃火柴。
4. 握住點火棒並將點燃的火柴插入燃燒器端口旁或是陶瓷板。
5. 壓下控制旋鈕並向左旋轉至「」設定，一直按著旋鈕直到燃燒器點燃為止。
6. 燃燒器應可立即被點燃。

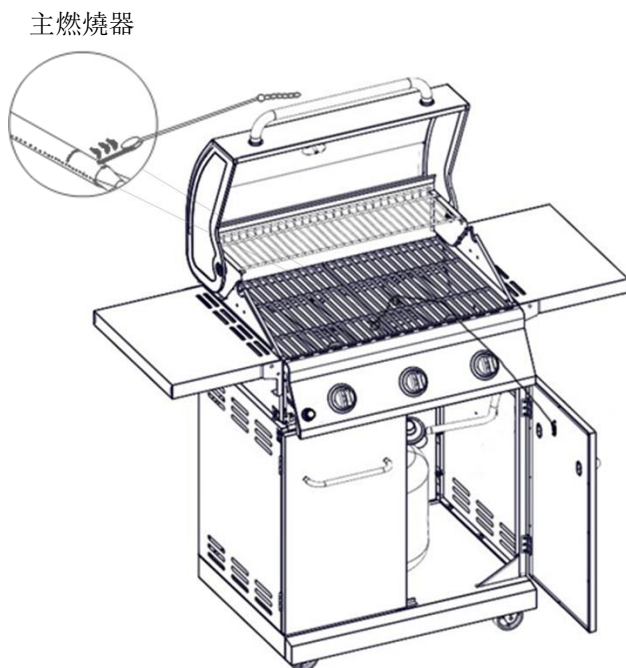

## 零件識別

**注意：** 在使用本烤爐前，請先拆除包括束帶的所有包裝材料。



主燃燒器

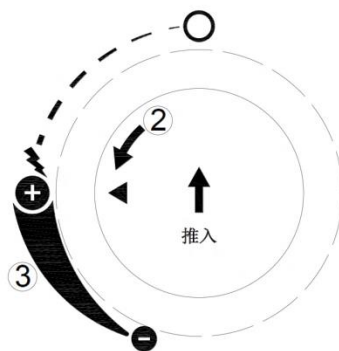

控制旋鈕，標籤

## 不鏽鋼

有多種不鏽鋼清潔劑可供使用。而最溫和無刺激性的清潔劑永遠為優先的選擇。順著產品的紋理方向擦洗清潔。切勿使用會刮傷表面的鋼刷。使用乾磨100#砂紙依表面紋理方向打磨，以修補不鏽鋼上面明顯的刮痕。油脂的污點會堆積於不鏽鋼表面，而經燒烤後表面會呈現鏽蝕。可使用柔軟的菜瓜布與不鏽鋼清潔劑去除髒污。

## 烤爐爐排

清理烤爐最簡單的方法即是在烹煮完成、與關火後立即清理。使用烤箱手套以保護雙手免受熱與蒸氣燙傷。以黃銅鬃毛烤肉刷沾水後刷洗熱燙的烤爐。不時以刷子沾著碗裡的水，而在清洗的過程因水接觸熱，產生的蒸氣會使食物碎屑軟化而有助於烤爐的清理。若烤爐在冷卻後才清理，會使得清洗更為困難。

**確認瓦斯供應及旋鈕是在「○」的位置。在移動之前確認烤爐的燃燒器上端已冷卻。**

## 烤爐燃燒器

在移動燃燒器時需特別留意，因在試圖重新點燃烤爐時，燃燒器孔口必須要確實地對齊。視使用烤爐的頻率定期進行清理。

## 主烤爐燃燒器的清潔

確認已關閉瓦斯供應，且旋鈕已就「○」位置。確認烤爐是處於冷卻的狀態。使用鋼絲刷清理燃燒器的外圍。以金屬刮刀清除頑強的污垢。可將迴紋針拉直來清理阻塞的端口。切勿使用木牙籤，因為木牙籤會折斷而堵住端口。請注意若發生昆蟲或是其他阻塞物阻礙瓦斯氣穿透燃燒器時，可能需要與我們的客服部門聯絡，美國當地請撥：1-866-984-7455，加拿大當地請撥：1-800-648-5864，我們提供英語、西語、法語的服務。來電請於太平洋標準時間，禮拜一至禮拜五上午8點至下午5點。

## 清理集油盤

集油盤必須清空以及定期地擦拭，並以溫和無刺激性的清潔劑與溫水溶劑清洗。可以放少量的沙於集油盤底部以吸收油脂。不時地檢查集油盤，勿讓多餘的油脂堆積並流出集油盤外。

**警告：若希望更換主燃燒器，我們強烈建議雇用受專業訓練的技術人員進行更換。請理解，我們對於因不正確的燃燒器組裝所導致的人身傷害，或是財產損失並不負任何責任義務。**

## 如何更換主燃燒器

**步驟1.** 使用尖嘴鉗移除位於火箱背板的主燃燒器R插銷。如下圖所示，以平頭螺絲起子將燃燒器上的引線遮蓋移開，之後移開火箱前板的主燃燒器。

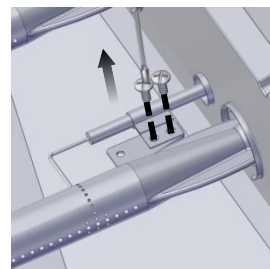
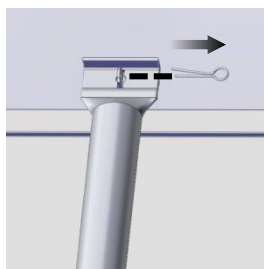

**步驟2.** 如下圖所示，將燃燒器裝回孔口處並固定燃燒器上的引線遮蓋，確認燃燒器的出火口對準孔口。

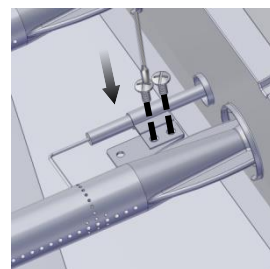
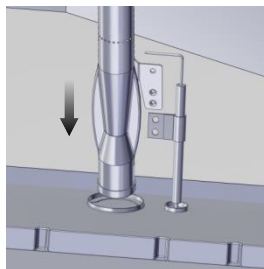

**步驟3.** 將主燃燒器以「R」插銷固定於火箱的背板。

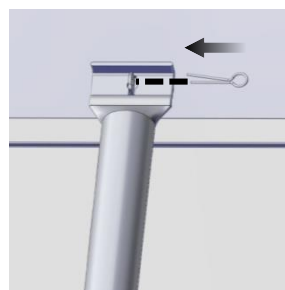

## 注意

1. 保持瓦斯戶外用烹飪裝置使用區域的清潔及保持周圍無可燃物質、汽油及其他可燃的揮發氣及液體。
2. 切勿阻礙燃燒及通風氣流的流通。
3. 放置瓦斯桶的封閉區域之通風口不受阻，且保持淨空。

## 蜘蛛及昆蟲的警告

檢查並清理燃燒器 / 文氏管中的昆蟲及昆蟲結網。管路阻塞會導致烤爐下方起火。雖然燃燒器管受阻並非造成「逆燃」的唯一因素，但它是最常造成「逆燃」的主因。要降低「逆燃」的發生機率，必須在組裝之前先清理燃燒器管，並且於夏末秋初蜘蛛活動最頻繁的時節，每月至少清理一次。若烤爐已經有一段時間未使用，也應依未使用過的程序清理燃燒器管。

## 何時查看是否有蜘蛛

每年至少應檢查一次，或是發生下列任何一種狀況都須立即檢查：

1. 接點聞到瓦斯味並且燃燒器的火焰呈現黃色。
2. 烤爐無法達到設定的溫度。
3. 烤爐的熱度不均。
4. 燃燒器發出啪啪的爆裂聲。

## 在打客服電話之前

在詢問客服部門之前若烤爐無法正常操作時，在與經銷商聯絡尋求維修服務之前請先使用以下的檢核表。或許您就可以省下電話費了。預熱：烤爐在預熱時必需關閉蓋板。在烹調某些食品之前必須先做預熱的步驟，依照食物的種類及烹煮的溫度而訂。需要高溫烹煮的食物需要先預熱五分鐘；需要以低溫烹煮的食物只須二至三分鐘的預熱時間。

## 烹調的溫度

高溫設定 — 使用此設定可快速的加熱，適用於燒烤牛排及肋排以及使用烤架時。

低溫設定 — 此設定適用於所有的燒烤、烘烤，以及烹煮瘦肉切片時使用，例如魚類。

這些溫度的設定會因外部溫度及風量而有不同。

以間接加熱烹煮時：可於烤爐的一側，利用燃燒器於另一側所產生的間接熱度，慢慢地烹煮出完美的家禽肉品及大切塊的肉類。由點燃的燃燒器所產生的熱氣會在烤爐中循環，在烹煮肉類及家禽肉品時不會直接與火焰接觸。這個方法使得烹煮 meat 時不會有火焰直接燒烤油脂及肉汁，大大的減少了在烹煮脂肪量特多的肉塊時發生突發火焰的狀況。

**注意：**若燃燒器在操作時熄滅，關閉瓦斯供應端並將所有的旋鈕關閉。打開蓋板並等五分鐘之後再嘗試重新點燃（這樣可讓累積的瓦斯氣消散）。

**注意：**若有油火產生，關閉瓦斯供應端及所有的燃燒器，並將蓋板關閉直到火焰熄滅為止。

**注意：**切勿在烤爐仍在操作時，試圖拆卸任何的瓦斯裝置配件。就如同所有的家電用具，適當的保養及維護會使它們保持最佳的操作狀況並延長使用壽命。您的烤爐也同樣需要獲得妥善的保養。

**注意：**邊爐若在使用時將蓋板蓋上，蓋板會變燙。

問題	解決方法
在試著點火時，烤爐不會馬上點燃。	<p>確認在點燃燃燒器時是否有火花產生（如果沒有火花的話）。檢查電池的安裝是否正確。</p> <p>確認電線與電極組連接。</p> <p>將電線以及 / 或是電極，使用酒精以紗布搓揉清理。</p> <p>以清潔的布料擦拭乾淨。</p> <p>查看其他的燃燒器是否可操作。若可以，檢查故障的燃燒器之瓦斯孔是否受阻</p>
調節器有噪音。	<p>調節器上的通風管可能堵塞或是調節器有缺陷。確認調節器上的通風管未受阻礙。清理管線，關閉瓦斯控制閥。等十分鐘後再次重新開啟。</p> <p>檢查火焰是否正常。若火焰不正常，請更換調節器。</p>

問題	解決方法
全尺寸的蓋板與烤爐尺寸不符。	蓋板可能和烤爐尺寸不符。這可能是因為太貼合。 確認蓋板的長度與烤爐的長度相符。 測量蓋板左到右的距離。再與烤爐的長度比較。 比較蓋板罩子部分與烤爐的位置及尺寸。 將蓋板展開並靜置，最好是放在暖和的陽光下或是溫暖的室內。 而烤爐側邊架子的蓋板由左到右用力壓入。
烤爐只能加熱到93-149° C / 200-300° F。	查看燃料管線是否彎折或是捲曲。 確認烤爐區內沒有灰塵。 確認燃燒器及孔口處保持乾淨清潔。 檢查是否有蜘蛛及昆蟲。 調節器有安全裝置，若有發生洩漏時會控制瓦斯流動。安全裝置可能會在沒有瓦斯洩漏時而啟動。 重新設定安全裝置時，關閉所有燃燒器及瓦斯開關。將調節器由瓦斯桶上拆下並靜待一分鐘。 重新將調節器裝回瓦斯桶，並慢慢地將瓦斯桶開關完全開啟。點燃所有的燃燒器並觀查溫度狀態。
烤爐預熱的時間長。	正常預熱至260-316° C / 500-600° F，需花費10-15分鐘的時間。天冷及強風時可能會影響預熱的時間。 若使用火山岩或是煤磚可能會增加預熱的時間及最高溫度。
燃燒器的火焰並非淡藍色。	火焰燃燒的空氣過多或是不足。 高度是主要的原因，然而天冷可能會影響空氣混合。可能需要調整燃燒器。 烤爐位處風大的位置。

## 訂購零件

### 如何訂購更換的零件

請參考37頁的零件明細，以確認取得正確的瓦斯烤爐更換零件。必需獲得以下資訊以確保獲得正確的零件。請注意，任何更換零件寄送的運費需由訂購者支付。

- 瓦斯烤爐型號（參考烤爐上的資訊貼標）
- 需要更換的零件之零件編號。
- 需要更換的零件之內容說明。
- 需要的零件數量。

為取得更換的零件，請與我們的客服部門聯絡。美國當地請撥：1-866-984-7455而加拿大當地請撥：1-800-648-5864；我們提供英語、西語、法語的服務。來電請於太平洋標準時間，禮拜一至禮拜五 上午8點至下午5點。

### 重要事項

僅使用工廠授權的零件。使用任何未經工廠授權的零件會造成危險。這也會使產品的保固失效。

保存本組裝及操作使用手冊以便於參考，也方便更換零件的訂購。

肉類的熟度，不論是一分熟、五分熟或是全熟，很大的程度是取決於肉塊的厚度。內行的大廚們說，要把切薄片的肉煮到一分熟，那簡直是不可能的事。烹調時間會因肉品的種類、尺寸大小及裁切的形狀、開始烹煮時肉類的溫度，以及烹調程度的喜好不同而受到影響。在解凍肉類食品時，建議將食物放冷藏過夜而不是使用微波爐解凍。這樣通常會使肉塊在烹煮時更為的汁多味美。用鏟子取代夾子或是叉子將肉翻面，因鏟子不會穿透肉的表面而讓肉汁流出。

為能得到最豐富甘甜的肉汁，在烹調完成後分別在肉的兩面進行調味或是加鹽，而肉只能翻面一次（翻面多次會使肉汁流失）。在肉的表面開始冒泡泡時再翻面。在開始燒烤肉品前先將多餘的脂肪處理掉。為免在烹煮時牛排或是肋排捲縮，沿著邊緣以每5公分（2英吋）的間距切開脂肪。

烹煮食物時切勿離開烤爐。

## 烤爐烹飪對照表

食物	重量或厚度	溫度熱定	時間設定	特別說明與提示
蔬菜				切片。沾些奶油或人造黃油。以厚鋁箔紙包覆。
新鮮甜菜根、胡蘿蔔、蕪菁		中溫	12到20分鐘	燒烤，翻面一次。偶爾塗上融化的奶油或人造黃油。
洋蔥	1.3公分 / 1/2英寸切片	中溫	8至20分鐘	以義大利醬汁、奶油或是人造黃油調味。
甜馬鈴薯 白馬鈴薯	整顆 170至226公克 / 6至8盎司	中溫 高溫	40至60分鐘 45至60分鐘	單個以厚鋁箔紙包覆。加以燒烤，偶爾翻面。
冷凍蘆筍、豌豆、四季豆、小洋白菜		中溫	15至30分鐘	沾些奶油或是人造黃油。以厚鋁箔紙包覆。加以燒烤，偶爾翻面。
炸薯條		中溫	15至30分鐘	放在鋁箔紙盤內。燒烤，偶爾攪拌翻面。
肉 牛肉 漢堡排	1-2公分 / 1/2 - 3/4英寸	中溫	10至18分鐘	燒烤，只須在表面烤出肉汁時翻面一次。在烤漢堡排時需全程注意，因突發火焰產生的速度很快。煮至內部溫度160度即可。
嫩腰肉		高溫	8至15分鐘	

食物	重量或厚度	溫度熱定	時間設定	特別說明與提示
一分熟	2.5公分/ 1英寸	高溫	8至14分鐘	除去邊緣油脂。燒烤，翻面一次。
五分熟	1.3公分/ 1/2英寸 2.5公分/ 1英寸 2.5 - 3.8公分 / 1-1/2英寸	高溫 中溫 至高溫	11至18分鐘 12至22分鐘 16至27分鐘	
全熟	2.5公分/ 1英寸 2.5 - 3.8 cm / 1-1/2英寸	中溫 中溫	18至30分鐘 16至35分鐘	
羔羊肉 厚肉片&牛排 一分熟	2.5公分/ 1英寸 2.5 - 3.8公分 / 1-1/2英寸	中溫 至 高溫	10至15分鐘 14至18分鐘	除去邊緣油脂。燒烤，翻面一次。
五分熟	2.5公分/ 1英寸 2.5 - 3.8公分 / 1-1/2英寸	中溫 至 高溫	13至20分鐘 18至25分鐘	
豬排	2.5公分/ 1英寸	中溫	20至30分鐘	除去邊緣油脂。燒烤，翻面一次。煮至喜好的熟度。
全熟	2.5 - 3.8公分 / 1-1/2英寸	中溫	30至40分鐘	
肋排		中溫	30至40分鐘	燒烤，偶爾翻面。 在完成前的幾分鐘刷上烤肉醬，並多次翻轉上色。
火腿排 (預煮的)	2.5公分/ 1英寸 切片	高溫	4至8分鐘	除去邊緣油脂。燒烤，翻面一次。
熱狗		低溫	5至10分鐘	切開表面。燒烤，翻面一次。
家禽	900至1400公克 / 2至3磅	低溫 至 中溫	最多一小時	有皮的那面朝上。燒烤，不時地翻面並塗上溶化的奶油、人造黃油、油或是滷汁。
雞胸 全熟		中溫	30至45分鐘	依喜好醃製。
魚類 及海鮮 大比目魚 鮭魚 劍魚	2至2.5公分 / 3/4至1英寸	中溫 至 高溫	8至15分鐘	燒烤，翻面一次。塗上溶化的黃油、人造黃油或油以保持溼潤多汁。
整支鮫魚 虹鱒魚	113至226公克 / 4至8 盎司	中溫 至 高溫	12至20分鐘	燒烤，翻面一次。塗上溶化的黃油、人造黃油或油。 塗上融化的奶油及檸檬汁。

**烤鮭魚**

2大塊鮭魚  
2大匙油  
鹽巴與胡椒粉  
57公克（2盎司）培根薄片  
2大匙奶油  
1大匙檸檬汁  
洋芹  
檸檬塊

預熱烤爐。鮭魚刷上油並以鹽巴及胡椒粉調味。擺放於烤爐內烹煮10分鐘，烹煮到一半的時間後將鮭魚翻面。同時，使用平底鍋於邊爐煎煮培根。將煮好的培根放在紙巾上吸附油脂。取奶油以小的深平底鍋加熱融化，小心不要讓奶油變色。鮭魚及培根擺盤。將奶油倒入並擠上檸檬汁。以洋芹及檸檬切片裝飾擺盤。用滾水煮熟的馬鈴薯加入奶油及灑上切碎的洋芹，搭配新鮮的生菜沙拉就可一起端上桌了。  
注意：鮭魚可以使用鱈魚、大比目魚或是鱈魚取代。

**烘烤辣味玉米**

6支中型玉米，去皮  
3大匙融化的奶油或是人造黃油  
少許小茴香粉  
少許芫荽籽粉

在開始烹煮前的半小時，玉米上塗抹奶油以便稍後烘烤。將每支玉米置於厚鋁箔紙上。其餘的調味料加入碗內，充分的混合。每支玉米刷上1-1/2大匙的奶油混合物。將鋁箔紙密封起來，擺入烤爐。烘烤時，偶爾翻轉包覆鋁箔紙的玉米，烤10—12分或是烤到全熟。

**TANGY SEAFOOD KABOBS**

0.45公斤（1磅）大蝦子，去殼並處理乾淨  
0.34公斤（3/4磅）干貝  
2/3 杯辣椒醬  
1/4杯蘋果醋  
奶油灑上切碎的香芹和新鮮的生菜沙拉

將蝦子及干貝於中型碗內混合。取小碗，把辣椒醬與以下的六項佐料混合。混合後的佐料倒入中型碗內。將蝦子及干貝均勻地裹上佐料。把加蓋的碗放入冰箱冷藏2小時。

3大匙切碎的香芹  
1大匙蔬菜油  
1大匙烏斯特辣醬油（醋）  
1/2大匙山葵粉  
1顆大蒜，切碎

1罐567公克的（20盎司）鳳梨罐頭，在

烹調前先將鳳梨瀝乾半小時。將烤爐的燃燒器全開。海鮮收乾保持醃料風味。以12支每支25.4公分（10英寸）的烤肉叉，將每2支蝦子、2個干貝加上一個鳳梨的順序替換，製作烤肉串。將烤肉叉放上烤爐。烹煮7-10分鐘，不時的塗上醬料並翻面。

**豬排**

4個豬排  
醬料  
1顆大洋葱  
2大匙檸檬汁或醋  
2大匙油  
1/2大匙芥末粉  
2大匙烏斯特辣醬油（醋）  
1/2大匙新鮮黑胡椒粉  
1大匙糖  
1/2大匙辣椒粉  
1顆大蒜

洋葱去皮，烘烤，除了豬排之外，加入所有的食材，充分混合。倒入豬排並置於涼爽的地方浸泡入味一小時。將爐火全數打開，加熱10分鐘。  
烘烤豬排，偶爾刷上滷汁醬料。混合的生菜沙拉淋上醋增加風味，加上蒔蘿就可一起端上桌。

**炙燒風味牛排**

4-6人份  
3/4杯義大利醬  
1大匙烏斯特辣醬油（醋）  
1大匙芥末粉  
1/4大匙百里香，壓碎  
1顆中型洋葱  
0.45公斤（1磅）牛腩排，肉表面用刀輕輕劃過  
2大匙融化的奶油

將前四項材料，加入洋葱混合，並以混合後的醬汁醃製牛腩排。放入冰箱冷藏至少四小時或是放整晚。取出牛排並放入已預熱的烤爐。每一面各烤5至7分鐘，不時以醬料塗牛排。同時，取出醬汁內的洋葱，置入平底鍋加入奶油於邊爐煎煮3分鐘。上桌前，將牛排斜切成細片，淋上洋葱。再以蔬菜串燒裝飾擺盤。

**馬鈴薯起司**

1-1/2杯切細的切達起司  
1罐（305公克（10-3/4盎司））奶油蘑菇濃湯  
1/3杯牛奶  
2大匙醬汁  
1/4大匙五香草  
1/4大匙鹽巴

1/8大匙胡椒粉  
4杯細切的馬鈴薯（4顆中型馬鈴薯）

將烤爐預熱。起司、濃湯、牛奶、烤肉醬、五香草、鹽巴及胡椒粉放入大碗內混合拌勻。將馬鈴薯混入攪拌均勻。將攪拌後的馬鈴薯放入已塗上1.42公升（1-1/2夸脫）奶油的長方型烤盤內。以鋁箔紙覆蓋烤盤。把覆蓋鋁箔紙的烤盤放入烤爐，蓋上蓋板以中溫烹煮25分鐘。將鋁箔紙拆下並持續再烤15分鐘，或是烤到馬鈴薯變鬆軟為止。在上桌前先靜置5分鐘。

**蔬菜串烤**

3顆中型的南瓜  
12顆聖女番茄  
12個新鮮蘑菇  
帕馬森起司磨碎

以邊爐將全數的南瓜煮5分鐘至半熟，或是煮到鬆軟。瀝乾並切成1.3公分（1/2英寸）的薄片。準備六支烤肉叉，陸續將每支烤肉叉串上南瓜、番茄及蘑菇。刷上以義大利醬、烏斯特辣醬油（醋）、芥末及百里香所製成的醬料。烤5-7分鐘並偶爾翻面並塗醬料。灑上大量的帕馬森起司。

**法士達（墨西哥烤肉）**

0.7公斤（1-1/2磅）牛腩排或去骨雞胸肉  
2大匙油  
1/2杯檸檬汁  
1/2小匙鹽巴  
1/2小匙芹菜籽鹽  
1/4小匙香蒜粉  
1/2小匙胡椒粉  
1/4小匙五香草  
1/4小匙小茴香  
墨西哥麵粉薄餅檸檬

拍打牛腩肉，使其厚度成為0.64公分（1/4英寸），或是將雞胸肉壓平。將油、檸檬汁混合並裝入夾鍊袋中調味。將肉放入袋內並搖晃，以便使肉能均勻上色並入味。放入冰箱冷藏整夜或是至少放置6至8個小時。將薄餅以鋁箔紙包起。取出袋內的肉，置入預熱的烤爐，每面烤5-8分鐘。在烤肉的同時，也將薄餅放入烤爐內烘烤。順著肉的紋路將肉切薄片。放入熱的盤子內。擠上檸檬汁。將肉和以下配料以薄餅包起：切碎的番茄、酪梨醬，酸奶油，塔可醬。



## 牛肉與羊肉串

4人食用

0.2公斤（1/2磅）去骨的沙朗或是牛肉切成2.5公分（1英寸）大小的塊狀 去骨的羊里脊肉切成2.5公分（1英寸）大小的塊狀

2/3杯的水, 分開  
1/4杯切碎的洋蔥  
2大匙醬油  
1/4杯蔬菜油, 分開  
1大匙黑糖  
1大匙新鮮檸檬汁  
2顆大蒜, 切碎  
1/4小匙小茴香粉  
1/4小匙芫荽籽粉  
1/4小匙薑黃粉  
1/8小匙紅辣椒粉  
1/8小匙薑粉  
1顆紅椒切塊  
1大條香蕉, 切塊 8個小蘑菇  
1/3杯香滑花生醬

攪拌器內加入1/3的水、洋蔥、醬油、2小匙油, 接著放入後面的8樣材料, 並攪拌至滑順。倒入肉塊並醃製4個小時, 偶爾翻面。收乾, 保持醬料風味。取四支30公分（12英寸）的烤肉叉, 每支分別依序穿上肉塊、紅椒、香蕉及蘑菇。預熱烤爐。將油塗於烤肉串上。每一邊烤7-8分鐘。將醬料置於深平底鍋並置於邊爐煮滾。加入剩下的1/3杯水及奶油。攪拌均勻。煮至熟透。若醬料過於濃稠, 加入1大匙的水。將煮好的醬汁與烤肉串一起上桌。

## 茄子魚子醬

1大條茄子  
2大匙橄欖油  
2大匙酒醋  
2大匙細切洋蔥  
1/2顆大蒜  
1顆中型番茄切碎, 鹽巴及胡椒切碎。

烤爐設定中溫燒烤茄子, 偶爾翻面直到烤熟為止。可能需要花費30分鐘的時間。由烤爐取出茄子並待其冷卻以便後續的處理。茄子去皮後切碎。加入所有的調味料。待冷卻後擺放在土司上, 就可上桌了。

## 印度風 - 唐杜里烤雞

8根大雞腿或是棒棒腿  
1杯原味去脂優格  
1/2杯檸檬汁  
2小匙鹽巴, 1/2小匙辣椒粉  
1/2小匙黑胡椒  
1/2小匙壓碎的大蒜  
1/2小匙磨碎的薑  
1大匙玉米油

將所有的材料放入碗內充分混合, 將雞肉放入醃料內並放入冰箱冷藏8小時。讓雞肉收乾, 並將烤肉鐵叉插入骨頭多肉的那面。以回轉式烤肉架燒烤雞肉。利用中高溫烹煮40分鐘, 以剩下的混合醃料偶爾塗抹調味。加上洋蔥、檸檬切片一起上桌。

## 肋排醃

醃料:  
1杯醬油  
1/2杯蜂蜜  
1/2杯醋  
1/2杯低糖雪莉酒  
2小匙切碎的大蒜  
2小匙糖  
1杯水  
1塊雞湯塊  
1罐啤酒做調味料使用

將排骨醃3小時。啤酒加入醬料內作為烤肉時的調味料。排骨下方放平底鍋並不時地塗上調味料。烹煮肋骨時, 挑選無脂肪肉量多的肋排, 並以烤肉鐵叉將肋排固定成扇形進行燒烤。將四叉烤肉固定座向下移動至鐵叉底端並加以固定。肋排的最前端至中央部位, 於第二肋骨處以鐵叉的尾部尖端刺入兩肋之間。跳過約兩個肋骨的距離, 再重新以同樣的步驟加以固定, 直到全數的肋排已成扇形固定於鐵架上。將第二支四叉烤肉固定座固定於烤肉鐵叉。將回轉式烤肉燃燒器開至高溫。燒烤50分鐘或是直到完成為止。

## 燒烤豬肉

蘋果醋醬汁:  
1杯蘋果醋  
170公克（6盎司）水半條奶油  
鹽、胡椒粉、香芹及大蒜調味  
57公克（2盎司）檸檬汁  
4.5公斤（10磅）燒烤用豬肉

時間: 1-1/2小時至2小時

在將豬肉插入烤肉架之前, 先讓豬肉恢復至室溫。放上烤肉架並檢查架子是否能平衡。將回轉爐燃燒器點燃。控制旋鈕轉至高溫。燒烤時使用以上材料所製成的醬汁調味。

## 火雞

5.4公斤（12磅）火雞  
啤酒醬汁:  
1罐啤酒  
340公克（12盎司）水  
1條奶油  
1小匙鹽巴  
1小匙胡椒粉  
1/2小匙蒜片  
1小匙香芹

將整隻雞完全解凍。雞隻內外清洗乾淨。將雞腿及雞翅固定好。點燃回轉式烤肉燃燒器, 調整至高溫。將所有材料放入淺的平底鍋內製作醬汁。鍋子置於火雞底部15-20分鐘。大約烹煮3小時。混合著火雞燒烤時滴落的醬汁, 能讓肉汁更為美味。

製造商僅針對本產品（型號720-0830MH）對原始消費者 - 購買者提供保固，保證本產品自購買日起至以下所表示的期間內，在經正確安裝及正常與合理的居家使用下不會因做工及材料因素而有所損壞。製造商保有要求提供損壞的佐證照片，或是要求損壞零件退回以做檢視及調查之權利，郵寄以及 / 或是運費應由消費者預付。Nexgrill所應承擔之責任依Nexgrill本身之選擇權，僅限於維修、更換或是折餘價值。

- **燃燒器管：**提供10年有限保固，保證不穿孔。
- **烤架與火焰控制器：**提供1年有限保固；並未包含摔落、剝落、刮痕或是表面受損。
- **不鏽鋼零件：**提供1年有限保固，保證不穿孔；並未包含諸如表面腐蝕、刮痕及生鏽等外觀問題。
- **其他所有零件：**提供1年有限保固（包含但未僅限於：閥門、框架、外殼、車架、控制面板、點火器、調節器、軟管）\* 並未包含剝落、刮痕、裂痕、表面腐蝕、刮痕或生鏽。

在消費者提供於此文有關的購貨證明時，製造商在證明瑕疵為保固期限內所發生後將提供維修或是更換零件服務。只要購買者是在自原始購買日起之保固期限內，除運送費用外，完成此類維修或是更換所需之零件將不再另外收費。依本有限保固之條件，原始消費者 - 購買者需負擔所有更換零件的運費。本有限保固僅適用於美國及加拿大，且僅適用於原產品之所有人使用並且不得轉讓。製造商需要有購買日期的合理證明。因此，必須留存銷售收據以及 / 或是發票。若本產品為別人贈送的禮物，可請求送禮的人將收據以你的名義，寄送回以下的地址。若未註冊或是無法提供購買證明，受本有限保固擔保之零件損壞或是遺失將無法進行更換。本有限保固僅適用於產品之功能性，並未包含諸如因熱度造成的變色、磨損以及化學清潔劑或是於組裝或安裝本裝置時使用的任何工具所造成的刮痕、凹陷、腐蝕、表面生鏽或是不鏽鋼表面變色等外觀問題。表面生鏽、腐蝕或是金屬零件的粉末塗料剝落，此類不會影響產品結構完整的狀況不能視為做工或是材料因素所產生的瑕疵，因此無法包含於本保固之範圍。本有限保固無法賠償您因而造成的不便、食材、人身傷害或是財產損失所滋生之成本費用。若原始的更換零件已無法取得，將會寄送相似的零件做為更換。依本有限保固之條件，您將負擔所有更換零件的運費。

#### 製造商不會負擔：

- 到府維修的服務。
- 當產品並未正常使用、非單一家庭或是非居家使用時，所要求的維修服務。
- 產品因意外、改裝、誤用、缺乏保養 / 清理、濫用、火災、水災、不可抗力、不正確之安裝，以及未依電氣或是管線規範所進行的安裝，或是誤用所造成的損害。
- 因產品故障所造成的任何食材損失。
- 在美國或是加拿大境外的零件更換或是維修的人工費用。
- 取貨及送貨的服務。
- 郵資或是供做資料存檔的照片之照相處理費用。
- 零件及系統之維修起因於未經授權而逕自對產品進行之改裝。
- 產品的拆裝以及 / 或是重新安裝。
- 保固範圍 / 非保固範圍以及零件替換的一般運費或是快遞運費。

#### 默示擔保之免責聲明：損害賠償之限制

於本有限保固之條件下，您所能獲得的唯一賠償為瑕疵零件的維修或更換。製造廠商並不負擔任何因間接或因違反此有限保固或是任何適用的默示擔保所引發而伴隨產生的損壞，或因不可抗力、不正確的保養及維護、油火、意外、改裝、非製造廠商所提供的更換零件、誤用、運送、商業使用、濫用、非良好的環境（惡劣的氣候、天災、動物破壞）、不正確的安裝或未依照當地法規或製造廠商印製的指示說明而產生之損壞賠償。

本有限保固為製造廠商所提供之唯一保固。除了本有限保固所列之事項外，所提及之產品性能規格或說明，在任何情況下皆未包含於製造廠商所應保固之事項範圍內。於各州法規所規定的任何默示擔保的保護，包括因特定目的或使用的適銷性或適應性之默示擔保，皆受到本有限保固規定之限制而受到約制。

若您希望得到有關於本有限保固提供何種責任義務的相關資訊，請寫信至：

**Nexgrill Customer Relations**  
**14050 Laurelwood Pl**  
**Chino, CA 91710**

有關於消費者退回、零件訂購、一般常見問題以及相關疑難的協助都可與我們的客服部門聯絡取得相關資訊。美國當地請撥：1-866-984-7455 而加拿大當地請撥：1-800-648-5864；我們提供英語、西語、法語的服務。來電請於太平洋標準時間，禮拜一至禮拜五上午8點至下午5點。

或寄送電子郵件至：[CostcoService@grillservices.com](mailto:CostcoService@grillservices.com)。

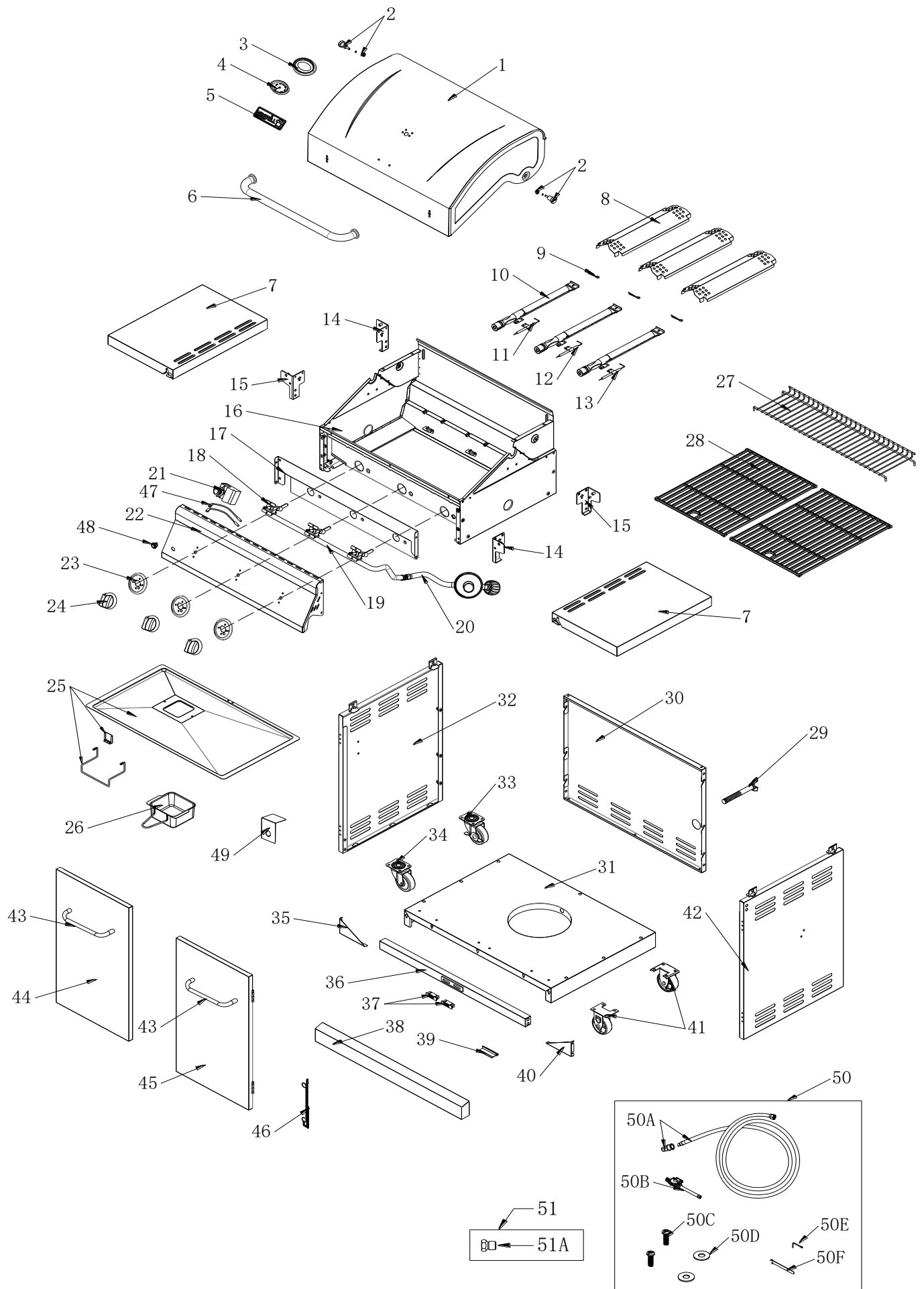

No.	Part (Description)	Warranty coverage (year)	QTY	No.	Part (Description)	Warranty coverage (year)	QTY
1	Main lid	1	1	32	Side panel, left	1	1
2	Main lid screw	1	2	33	Swivel caster with Brake	1	1
3	Temperature gauge Housing	1	1	34	Swivel caster	1	1
4	Temperature gauge	1	1	35	Triangle bracket, left	1	1
5	Logo	1	1	36	Cart frame	1	1
6	Main lid handle assembly	1	1	37	Door magnet	1	2
7	Side shelf	1	2	38	Bottom panel trim piece	1	1
8	Flame tamer	1	3	39	Door iron piece	1	1
9	Burner pin assembly	1	3	40	Triangle bracket, right	1	1
10	Main burner	10	3	41	Caster	1	2
11	Main burner igniter wire A	1	1	42	Side panel, right	1	1
12	Main burner igniter wire B	1	1	43	Door handle assembly	1	2
13	Main burner igniter wire C	1	1	44	Door, left	1	1
14	Side shelf support bracket A	1	2	45	Door, right	1	1
15	Side shelf support bracket B	1	2	46	Lighting rod	1	1
16	Main burner bowl assembly	Non-replaceable	1	47	Pulse Igniter Wire	1	2
17	Front baffle	1	1	48	Pulse Igniter Button	1	1
18	Main gas valve	1	3	49	Ignition Module Heat Shield	1	1
19	Main manifold	1	1	50	NG Conversion kit	Sold separately as set	
20	LP regulator with Hose	1	1	50A	NG gas hose with quick connector assembly	Sold separately with #50	1
21	Electronic igniter module	1	1	50B	NG Regulator assembly		1
22	Main control panel	1	1	50C	Truss head screw		2
23	Bezel	1	3	50D	Flat Washer		2
24	Control knob	1	3	50E	6 mm Nut Driver		1
25	Grease tray assembly	1	1	50F	6 mm Wrench		1
26	Grease box	1	1	51	NG orifice pack	1	1
27	Warming rack	1	1	51A	Main burner NG orifice $\phi$ 1.75mm	1	3
28	Cooking grid with hole	1	2		Grill cover		1
29	Tank bolt	1	1		Assembly Manual		1
30	Rear panel	1	1		Operation Manual		1
31	Bottom panel	1	1		Hardware pack		1

編號	零件說明	保修範圍 (年)	數量	編號	零件說明	保修範圍 (年)	數量
1	主蓋	1	1	32	左側面板	1	1
2	主蓋螺絲	1	2	33	剎車腳輪	1	1
3	溫度表外殼	1	1	34	腳輪	1	1
4	溫度表	1	1	35	左三角支架	1	1
5	品牌標誌	1	1	36	烤爐架	1	1
6	主蓋手柄組件	1	1	37	門板磁鐵	1	2
7	邊桌	1	2	38	底板裝飾件	1	1
8	火焰分佈器	1	3	39	門板鐵件	1	1
9	燃燒器銷組件	1	3	40	右三角支架	1	1
10	燃燒器銷組件	10	3	41	腳輪	1	2
11	主燃燒器點火線A	1	1	42	右側面板	1	1
12	主燃燒器點火線B	1	1	43	門把手總成	1	2
13	主燃燒器點火線C	1	1	44	左門	1	1
14	邊桌支撐架A	1	2	45	右門	1	1
15	邊桌支撐架B	1	2	46	點燃棒	1	1
16	主燃燒器爐體組件	不可更換	1	47	點火器線	1	2
17	前擋板	1	1	48	點火按鈕	1	1
18	主燃氣閥	1	3	49	點火模塊隔熱罩	1	1
19	主歧管	1	1	50	NG轉換套件	單獨出售	
20	帶軟管的LP氣體調節器	1	1	50A	NG氣管，帶快速接頭組件	與 #50分開出售	1
21	電子點火器模塊	1	1	50B	NG調節器組件		1
22	主控制面板	1	1	50C	桁架頭螺釘		2
23	外框	1	3	50D	平墊圈		2
24	控制旋鈕	1	3	50E	6毫米螺母驅動器		1
25	油脂盤組件	1	1	50F	6毫米扳手		1
26	油脂盒	1	1	51	NG孔板包裝	1	1
27	保溫架	1	1	51A	主燃燒器NG孔 $\phi$ 1.75毫米	1	3
28	帶孔烹飪網	1	2		爐蓋		1
29	油箱螺栓	1	1		組裝手冊		1
30	後面板	1	1		操作手冊		1
31	底面板	1	1		硬件包		1

Costco President Taiwan, Inc.  
No. 656 Chung-Hwa 5th Road  
Kaohsiung, Taiwan  
Company Tax ID: 96972798  
449-9909 or 02-449-9909 (if  
cellphone)  
[www.costco.com.tw](http://www.costco.com.tw)

MADE IN CHINA  
中國製造