



145, Brea Canyon Road
Walnut, CA 91789, U.S.A.

GAS-FIRED INFRARED OUTDOOR PATIO HEATER INSTALLATION, OPERATION MAINTENANCE INSTRUCTIONS



PTH-105

TABLE OF CONTENTS

	PAGE
IMPORTANCE	1
TOOLS & PARTS	2
PRECAUTIONS.....	3
ASSEMBLY INSTRUCTIONS	4
GAS REQUIREMENTS & LEAK TESTING	8
SAFETY CHECKS	9
LOCATING HEATER FOR USE	10
LIGHTING / SHUTDOWN	12
STORAGE / BURNER REMOVAL.....	13
BURNER INSTALLATION / PILOT CLEANING	14
BURNER REMOVAL	15
TROUBLE SHOOTING	16
PARTS LIST	17
WARRANTY	18

READ THE FOLLOWING INSTRUCTIONS CAREFULLY AND BE SURE YOUR PATIO HEATER IS PROPERLY INSTALLED, ASSEMBLED AND CARED FOR. FAILURE TO FOLLOW THESE INSTRUCTIONS MAY RESULT IN SERIOUS BODILY INJURY AND/OR PROPERTY DAMAGE. IF YOU HAVE QUESTIONS CONCERNING ASSEMBLY OR OPERATION, CONSULT YOUR DEALER, GAS APPLIANCE SERVICE REPRESENTATIVE OR YOUR GAS COMPANY.

NOTE TO INSTALLER:

LEAVE THESE INSTRUCTIONS WITH THE CONSUMER AFTER INSTALLATION.

NOTE TO THE CONSUMER:

RETAIN THESE INSTRUCTIONS FOR FUTURE REFERENCE.

DOMESTIC USE ONLY



**PLEASE CONTACT 1-800-913-8999 FOR ASSISTANCE.
DO NOT RETURN TO PLACE OF PURCHASE.**

*** * * IMPORTANT NOTICE:**

DO NOT return to place of purchase!!!

Please contact Customer Service hotline at 800-913-8999 for help.

IMPORTANT

*** * * WARNING * * ***

For outdoor use only (outside any enclosure)

Improper operation, installation, adjustment, alteration, servicing or maintenance can cause severe property damage or serious injury or death. Please read the installation, operation & maintenance instructions thoroughly before installing or servicing this equipment.

*** * * FOR YOUR SAFETY * * ***

If you smell gas:

- Shut off gas to appliance.
- Extinguish any open flame.
- If odor continues, immediately call your gas supplier.

For your safety:

Do not store or use gasoline or other flammable vapor and liquids in the vicinity of this or any other appliance.

TOOLS AND PARTS NEEDED FOR ASSEMBLY

NOTE: 20 pound, 5 Gallon LPG Tank is not supplied

Tools Needed:

Adjustable Opening Wrench
Spray Bottle of Soapy Water (to check for leaks)

Parts Supplied:

Reflector (3)
Reflector Dome Cap (1)
Reflector Plate (1)
Heater Head Assembly (1)
Post Assembly (2)
3/8" X 40 1/2" Galvanized Supply Pipe (1)
LPG Gas regulator (1)
Weighted Base with LPG Tank Cover Assembly (1)

Hardware Package

Reflector Nut (1)
1/4" x 3 1/2" Long Thread Ends Stud
Reflector 5/32" Screw (3)
Reflector Plate 1/4" Truss Head Screw (3)
Post 1/4" Truss Head Screw (4)
Post 1/4" Split Lock (4)
Post 1/4" Nut (4)
Teflon Plumbing Tape For Joints (1)
Spanner for Retention Kit(1)

For Service Questions Replacement parts or other assistance, Please call Nexgrill Customer Service Hotline at:

Nexgrill
145 Brea Canyon Road
Walnut, CA 91789
(800) 913-8999

*** * * IMPORTANT NOTICE:**

DO NOT return to place of purchase!!!

Please contact Customer Service hotline at 800-913-8999 for help.

PRECAUTIONS

NOTE: PLEASE READ THE FOLLOWING SAFETY

- Do not use this space heater in an explosive atmosphere. Keep heater away from areas where gasoline or other flammable liquids or vapors are stored.
- Prior to use, check for damaged parts such as hoses regulators, pilot or burner.
- Do not attempt to alter unit in any manner. **EXAMPLE:** using the heater without the top canopy reflector or radiant screen. Do not shorten the burner post assembly.
- Heater must always be placed on a solid and level surface.
- Always maintain proper clearance to combustible materials.(Top 18" Side 24")
- Always assure there is ample fresh air ventilation for outdoors use **ONLY**.
- Never replace or substitute the regulator with any regulator other than the factory suggested replacement.
- Do not clean heater with cleaners that are combustible or corrosive.
- Do not paint radiant screen, control panel or top canopy reflector.
- All leak test should be done with a soapy solution. NEVER USE AN OPEN FLAME TO CHECK FOR LEAKS.
- The LP tank should be turned off when the heater is not in use.
- At least once a year, the unit should be inspected for the presence of spiders, spider webs or other insects. The burner area is a common spider haven and can damage the heater and render it unsafe for use, Check the heater immediately if any of the following exists:
 1. The smell of gas in conjunction with extreme yellow tipping of the burner flames.
 2. The heater does not reach temperature.
 3. The burner makes popping noise during use (a slight popping noise is normal when the burner is extinguished).
- The LP regulator/hose assembly shall be located out of pathways where people may trip over it or in area where the hose will not be subject to accidental damage.
- Children and adults should be aware of hazards of high surface temperature and shall stay away to avoid burns of clothing ignition.
- Young children should be carefully supervised when they are in the area of the heater.
- Clothing or other flammable material should not be hung from the heater, or placed on or near the heater.
- Any guard or other protective device removed for servicing the heater must be replaced prior to operating the heater.
- Installation and repair should be done by a qualified service person, the heater must be should be inspected before use and at least annually by a qualified service person. More frequent cleaning may be required as necessary. It is imperative that control compartment, burner and circulating air passageways of the heater be kept clean.
- Keep the appliance area clear and out of combustion material, gasoline and other flammable vapors and liquids.
- Do not obstruct the flow of combustion and ventilation air.
- Keep the ventilation opening of the cylinder enclosure free and clear of debris.

*** * * IMPORTANT NOTICE:**
DO NOT return to place of purchase!!!
Please contact Customer Service hotline at 800-913-8999 for help.

ASSEMBLY INSTRUCTIONS

NOTE: Assembly of this heater requires basic mechanical skills. Proper assembly is the responsibility of the installer.

STEP 1: Gas pipe

- Cover threads with provided Teflon tape or gas pipe sealant before connecting regulator hose.

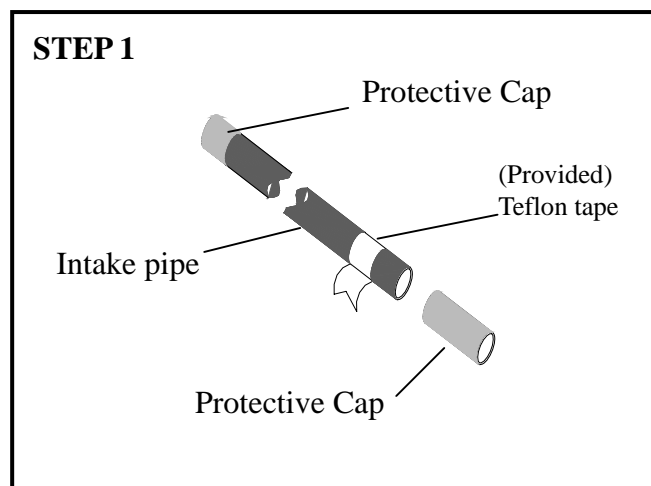

STEP 2: Secure the Gas pipe & Post

- Thread the intake pipe clockwise into the safety valve tightly.
- Slide the intake pipe through the top of the post and down through the hole in the top of the tank enclosure and secure the heating unit to the top of the post.

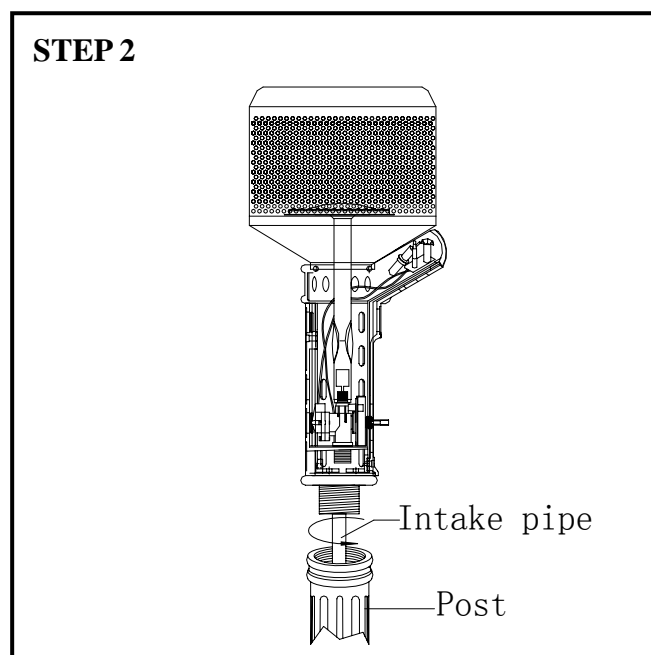

*** * IMPORTANT NOTICE:**

DO NOT return to place of purchase!!!

Please contact Customer Service hotline at 800-913-8999 for help

ASSEMBLY INSTRUCTIONS

NOTE : Assembly of this heater requires basic mechanical skills Proper assembly is the responsibility of the installer.

STEP 3: Connect post to cylinder enclosure

- Secure two post together. Then place post on of cylinder enclosure. Fasten 1/4 inch X 1 1/2 inch machine screws to the top of the cylinder to and screws on machine nut.

CAUTION: It will take about 5 minutes to bleed the gas line, so be patient.

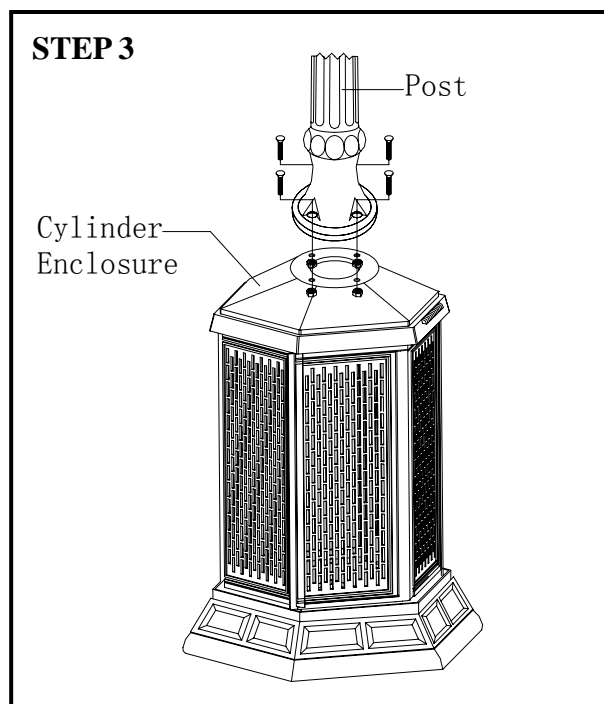

*** * * IMPORTANT NOTICE:**
DO NOT return to place of purchase!!!
Please contact Customer Service hotline at 800-913-8999 for help

ASSEMBLY INSTRUCTIONS

NOTE: Assembly of this heater requires basic mechanical skills. Proper assembly is the responsibility of the installer.

STEP 4: Attach the reflector

- Secure the 1/4" X 3 1/2"L threaded ends stud into emitter top.
- Attach the reflector and reflector cap to the top of emitter grid ornamental final. It screws on to 1/4" X 3 1/2 "L threaded stud screwed into emitter top.

NOTICE:

EMITTER GRID COLORATION OCCURRED DURING OUR TEST STAGE. THIS WAS PERFORMED TO ENSURE YOUR SAFE USAGE

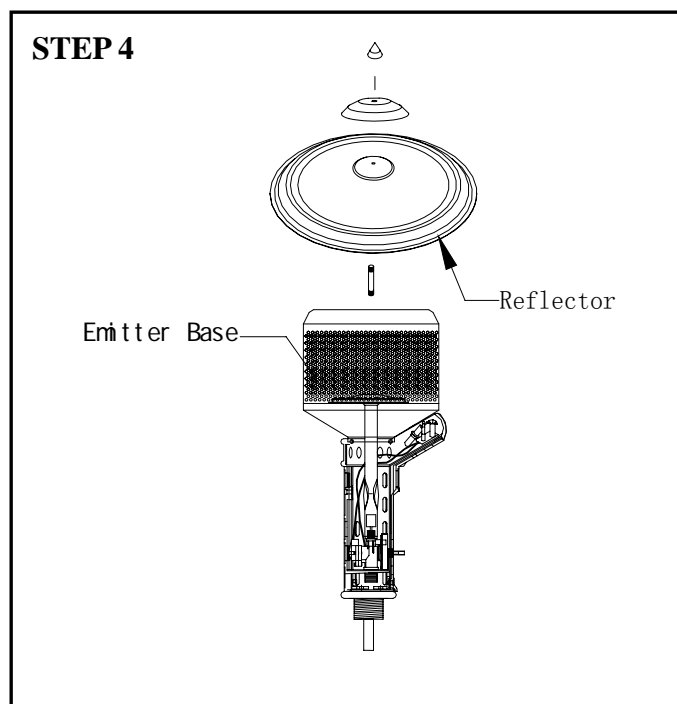

STEP 5: Attach regulator

- Attach 3/8 inch flare adapter on the hose end of the regulator assembly to the flare fitting on the intake pipe.
- Secure the other end of regulator inlet fitting onto gas tank until tight.
- The 3/8 inch female IPS X 3/8 inch male flare fitting is already attached on the intake pipe by manufacturer.
- The LP-Gas supply cylinder must be disconnected when this appliance is not in use. Disconnect the gas tank by turning the regulator anti-clockwise.

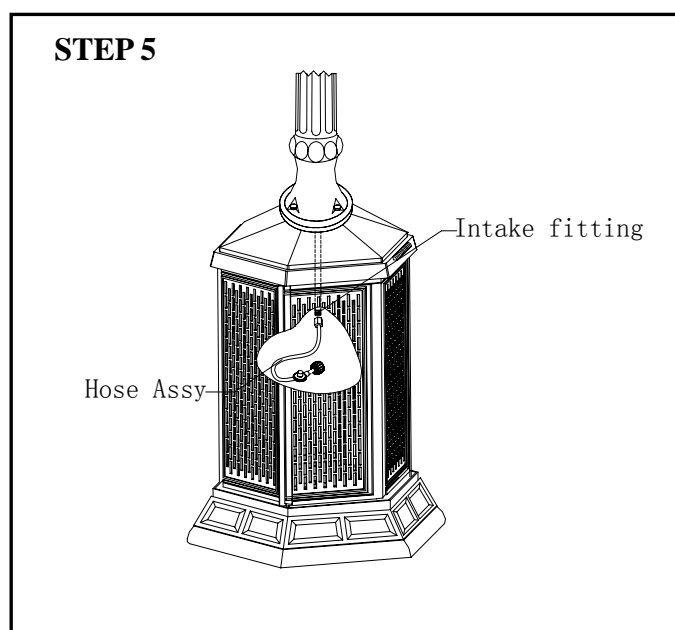

*** * * IMPORTANT NOTICE:**

DO NOT return to place of purchase!!!

Please contact Customer Service hotline at 800-913-8999 for help

ASSEMBLY INSTRUCTIONS

NOTE: Assembly of this heater requires basic mechanical skills. Proper assembly is the responsibility of the installer.

STEP 6: Attach the Retention Kit

- Loose the retention kit with spanner, then put in the gas tank.
- Secure the retention kit with spanner as shown in the right figure.
- Attach the regulator to the gas tank.

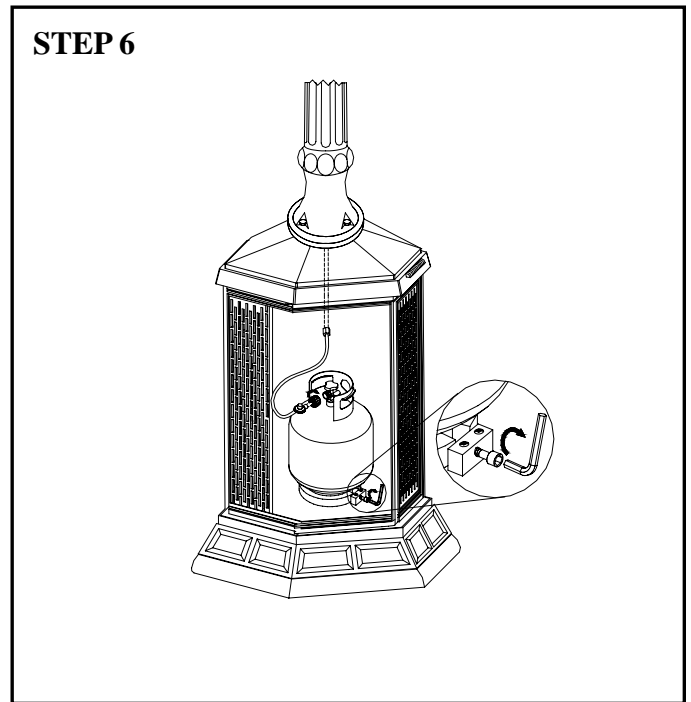

*** * * IMPORTANT NOTICE:**

DO NOT return to place of purchase!!!

Please contact Customer Service hotline at 800-913-8999 for help.

GAS REQUIREMENTS & LEAK TESTING

NEVER CONNECT AN UNREGULATED GAS SUPPLY TO THE HEATER

PRECAUTIONS

- Periodically check the whole gas system for leaks or immediately check if the smell of gas is detected
- Extinguish all open flames.
- Never leak test while smoking.
- If you cannot stop a leak, turn off the gas supply and call the Customer Service hotline, the dealer where you made the purchase or your gas supplier.
- The heater must be checked with a full cylinder.
- Do not use the heater until all connections have been leak tested and do not leak.
- Only those parts recommended by the manufacturer should be used. Substitution can void the warranty.
- A dented, rusted or damaged propane tank may be hazardous and should be checked by your tank supplier. Never use a propane tank with a damaged valve connection.
- The propane tank must be constructed and marked in accordance with the specifications for LP gas cylinders of the US Department Of Transportation (DOT)
- The propane tank must be arranged to provide for vapor withdrawal from the operating cylinder
- Never connect an unregulated propane tank to the heater

GAS REQUIREMENTS

- The pressure regulator provided with this heater must be used. This regulator is set for L.P. / Propane units at 10.0" W.C.
- Maximum inlet pressure to propane regulator must not exceed 100 PSI.
- A minimum supply pressure of 11.0 W.C. is required for the purpose of input adjustment for propane gas.
- The pressure regulator and hose assembly supplied with the appliance must be used. Replacement pressure regulator and hose must be specified by the appliance manufacturer.
- The installation must conform with local codes or in the absence of local codes, with National Fuel Gas Code, ANSI Z223.1-1996.
- The heater comes equipped with a hose assembly for hook-up to a standard propane gas tank. The propane tank is not included..

LEAK TESTING

- Gas connections on the heater are leak tested at the factory prior to shipment a complete gas tightness check must be performed at the installation on site due to possible miss handling in shipment or excessive pressure being applied to the heater.

TO LEAK TEST

- Make a soap solution of one part liquid detergent and one part water. The solution can be applied with a spray bottle brush or rag. Soap bubbles will appear where a leak is present
- Make certain the safety control valve is in the 'OFF' position
- Turn the gas supply 'ON'.
- If a leak is present turn 'OFF' the gas supply, tighten any leaking fitting, turn gas supply 'ON' and recheck

*** * * IMPORTANT NOTICE:**
DO NOT return to place of purchase!!!
Please contact Customer Service hotline at 800-913-8999 for help

SAFETY CHECKS

ALWAYS CHECK THE FOLLOWING CONNECTIONS

STEP 1

1. Check connection of regulator to the propane tank connection. Remember, the POL adapter is a left hand thread
2. Check all connections on the hose regulator assembly
3. Check the intake pipe to make certain that it is not kinked or in a position that could cause it to kink hand tighted and than make a 1/2 turn with the adjustable wrench

NOTE: The remaining connections are to be Tested after the heater has been lit
(SEE LIGHTING INSTRUCTIONS)

STEP 1

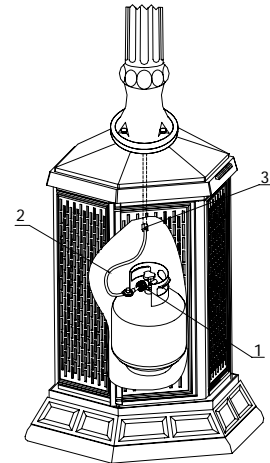

STEP 2

4. Light the heater following instructions on page 10 and page 11.
5. Using spray bottle with soapy water, spray each of the areas listed below to visually inspect for leaks. leaks will be indicated by bubbles.
6. Check intake pipe fitting at the bottom of safety control valve.
7. Check pilot tubing to safety control valve
8. Check orifice fitting and the safety control valve
9. Check pilot tubing and pilot

NOTE: After leak testing is completed and all leaks are sealed , close the door to the tank enclosure and your patio heater is ready to use.

STEP 2

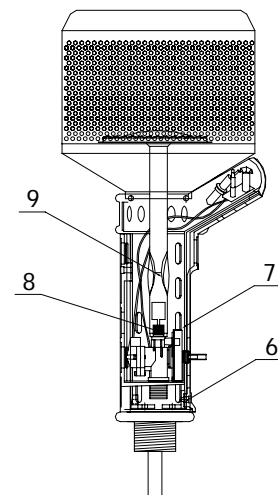

*** * * IMPORTANT NOTICE:**

DO NOT return to place of purchase !!!

Please contact Customer Service hotline at 800-913-8999 for help

LOCATION HEATER FOR USE

BE CAREFUL: When certain materials or items are left under this heater, while in use, they will be subject to radiant heat and could be seriously damaged.

- The unit is designed for heating outdoor patios, decks, spas, pool and working areas.
- Always ensure that adequate fresh air ventilation is provided. Follow the spacing tolerances in Figure 1.
- The minimum clearances to combustibles construction shown in Figure 1 must be maintained at all times
- The installation must conform to local codes or in the absence of local codes with the standard for the storage and handling of liquid petroleum gases:

In the US use : ANSI/NFPA58 on National Fuel Gas Code ANSI Z223-1998

In Canada use: National Standards of Canada. CAN/CGA B149.1 & 2-M86

- The heater must be placed on level firm ground.
- Never operate in an explosive atmosphere. Keep away from areas where gasoline or other flammable liquids or vapors are stored or used.



During strong and windy weather, turn off the heater and the gas cylinder valve. Remove the heater reflector hood then move the heater to a sheltered location. Cautions do not move heater while it is still hot.

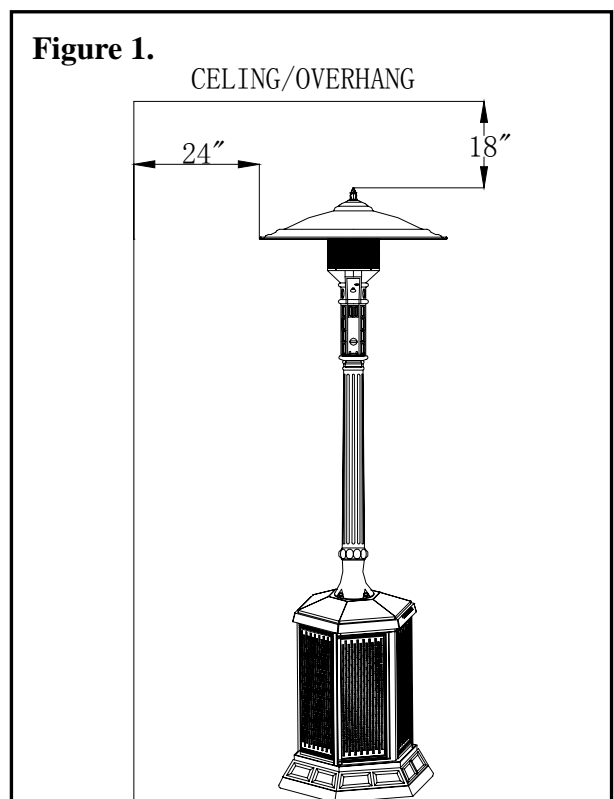

*** * * IMPORTANT NOTICE:**

DO NOT return to place of purchase !!!

Please contact Customer Service hotline at 800-913-8999 for help

LIGHTING/SHUTDOWN

BEFORE TURNING THE GAS SUPPLY 'ON':

Visually inspect the hose assembly for evidence of excessive abrasion cuts or wear. If the hose leaks it must be replaced prior to use. The hose replacement shall be that specified by the manufacturer. See parts list or details, then call Customer Service hotline.

Is the surrounding area free of combustible materials, gasoline and other flammable vapors or liquids?

BEFORE LIGHTING:

For your safety, if re-lighting a hot heater.

Always wait at least five (5) minutes.

NOTE: 20 pound, 5 Gallon LPG Propane Tank must be used.

TO LIGHT:

- (A) Open tank enclosure door.
- (B) Make certain hose is connected to the heater intake pipe and regulator is connected to the propane tank. Check both connections to ensure they are tight and leak proof.
- (C) Turn supply tank valve in a counter clockwise direction. Check for leaks by applying soapy water to the tank and hose connections.
- (D) (See Figure 2) Push and turn the gas control knob to 'PILOT' position. (The igniter will spark at the same time. Firmly press-down the knob for 15 seconds until the pilot remain lit. It might need 2 or 3 trials to light the pilot burner. If the pilot fails to remain lit or becomes extinguished. Repeat steps B-D.
- (E) Once the pilot is lit continue to hold in the control knob for 15seconds or the until pilot remains lit after knob is released.
- (F) The burner may now be turned to the full on position and then reduced to the desired heat range.

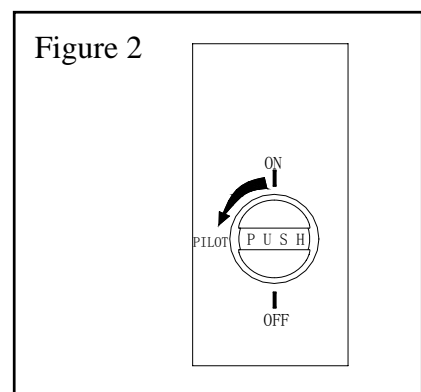

Caution: Avoid inhaling fumes emitted from the heater's first use. Smoke and odor from the burning of oils used in manufacturing will appear. Both smoke and odor will dissipate after approximately 30 minutes. The heater should NOT produce thick black smoke.

NOTE: The burner may be noisy when initially turned on. To eliminate excessive noise from the burner, turn the Control Knob to the pilot position. Then turn the knob to the level of heat desired.

*** * * IMPORTANT NOTICE:**

DO NOT return to place of purchase !!!

Please contact Customer Service hotline at 800-913-8999 for help

LIGHTING/SHUTDOWN

WHEN HEATER IS ON:

- Emitter screen will become bright due to intense heat. The color is more visible at night.
- Burner will display tongues of blue and yellow flame. These flames should not be yellow or produce thick black smoke, indicating an obstruction of airflow through the burners. The flame should be blue with straight yellow tops.
- The flame pattern at the emitter grid should be visually checked whenever heater is operated (see figure 2). If flames extend more than 1/2 inch beyond surface of the emitter grid or reflector the heater should be turned off immediately and the heater should not be operated again until repairs are made

FIGURE 3
NORMAL FLAME POSITION

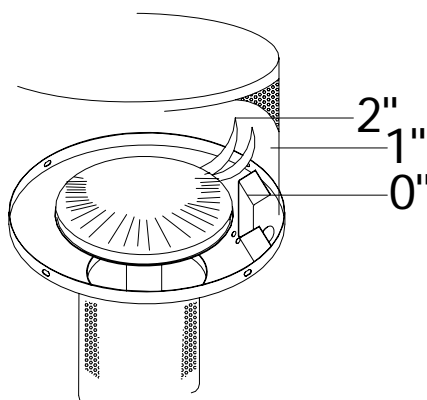

RELIGHTING

- Turn the control knob to off position.
- Wait five (5) minutes before attempting to relight pilot.
- Repeat steps beginning with step (D) above.

SHUT DOWN INSTRUCTIONS:

- Turn control knob clockwise to 'OFF' position. The burner may make a slight popping sound when extinguished. This is normal.
- Turn propane tank gas valve clockwise to 'OFF' position when heater is not in use

Caution: This patio Heater contains a Tilt Safety Switch which is designed to provide safe use of the patio heater. The tilt safety switch will automatically shut-off the heater when it tilts in the tip angle over 45-60 degrees from vertical position.

*** * * IMPORTANT NOTICE:**

DO NOT return to place of purchase !!!

Please contact Customer Service hotline at 800-913-8999 for help

STORAGE/BURNER REMOVAL

WHEN STORING THE HEATER THE CONNECTION BETWEEN THE PROPANE TANK AND THE HEATER MUST BE DISCONNECTED AND THE PROPANE TANK REMOVED FROM THE ENCLOSURE AND STORED INDOORS IN A WELL VENTILATED AREA OR IN ACCORDANCE WITH CHAPTER 5 OF THE STANDARD FOR THE STORAGE AND HANDLING OF LIQUEFIED GASES, ANSI/NFPA 58-1998.

CLEANING:

Your heater will last longer if maintained properly. It is important that the flow of combustion air must never be obstructed. Orifice and air openings must be kept free of dirt and spider webs. Never use a cleaning agent which is flammable or corrosive.

It is recommended that the heater body components; from the burner head down, are periodically protected with a coat of automobile wax .

If repainting is necessary, paint only the post/base assembly. Never paint the reflector, emitter assembly the safety control valve cylinder, valve panel or instruction plate on post.

The posts of the burner must remain clean so that the gas flow is unrestricted. The air inlet of the venturi tube must also be kept clean for combustion air supply if the heater is not performing properly it may be necessary to clean the burner (see burner removal).

BURNER REMOVAL:

1. Remove reflector and emitter assembly by removal of the screws that fasten the emitter assembly to the lower screen cone .
2. Remove the burner by unscrewing the burner from the top of the valve body.

Any debris in the opening of the burner assembly can be cleared with a straightened piece of coat hanger. Any rust can be removed carefully with a wire brush. Never use a piece of wood or other materials that might break off and block the ports.

Caution: Bugs and small insects easily get into the burner, gas orifice and burner check unit before using after a period of storage of heater.

Tips: Lighting the Patio Heater once a month will ensure your heater remains in good working condition.

*** * * IMPORTANT NOTICE:**
DO NOT return to place of purchase !!!
Please contact Customer Service hotline at 800-913-8999 for help

BURNER INSTALLATION/PILOT CLEANING

BURNER INSTALLATION:

Install the burner assembly by reversing the four (4) steps used for disassembly making certain the burner assembly stands centered when complete.

After reassembly, the heater should be test fired. Observe the burner flame. The flame should be blue with a slight yellow tipping.

PILOT CLEANING:

The pilot burner provides a flame to light the main burner. It also heats a thermocouple which must be hot before allowing the main burner to come on.

If the pilot is blocked by debris, spider webs, etc., the pilot flame may be small and the thermocouple may not heat up enough for the main burner to come on. If this occurs it will be necessary to clean the pilot.

BEWARE OF SPIDERS



CAUTION : BURNER TUBES MUST BE INSPECTED AND CLEANED BEFORE FIRST USE

Spiders and small insects occasionally spin webs or make nests in the burner tubes and orifices during warehousing and transit these webs or nests can lead to a gas flow obstruction which could result in a fire on and around the burner tubes. This type of fire is known as FLASH BACK and can cause serious damage to your patio heater and create an unsafe operating condition for the user. Although an obstructed burner tube is not the only cause of FLASH BACK it is the most common cause and frequent inspections and cleaning of the burner tubes is necessary .

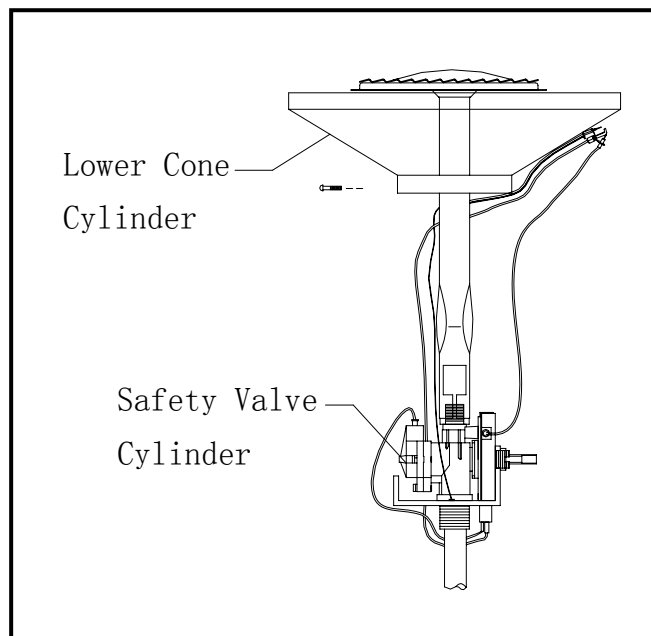

*** * * IMPORTANT NOTICE:**

DO NOT return to place of purchase !!!

Please contact Customer Service hotline at 800-913-8999 for help

BURNER REMOVAL

START DISASSEMBLY FOR CLEANING BY:

1. Remove the valve panel to gain access to the pilot.
2. Remove screw that fastens the pilot assembly to the lower screen cone.
3. Hold the pilot assembly with slip joint pliers, loosen and remove the nut at the base of the pilot.
4. Inspect the pilot and tubing for blockage, you should be able to see through the pilot. If it is obstructed by debris clear with a piece of wire.
5. The cap-like pilot orifice can be cleared with a pin. Use the pin gently on the inside of the orifice to clear debris. Never enlarge the opening of the pilot orifice.

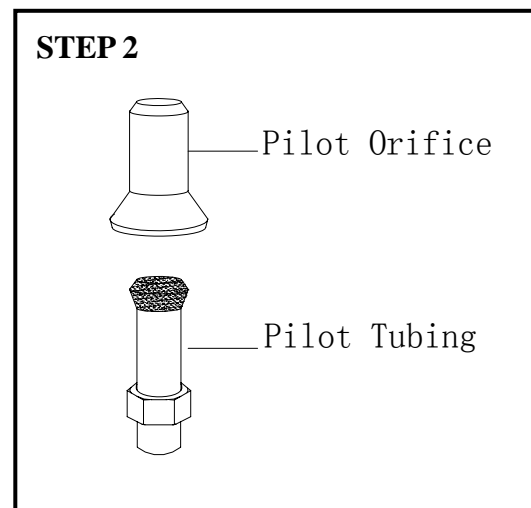
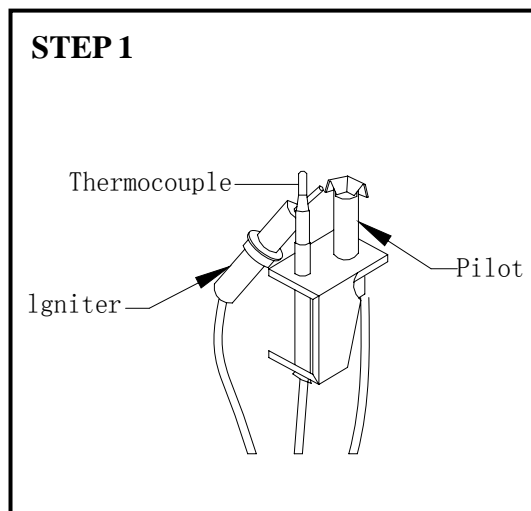

*** * * IMPORTANT NOTICE:**

DO NOT return to place of purchase!!!

Please contact Customer Service hotline at 800-913-8999 for help.

TROUBLE SHOOTING

Problem	Possible Causes	Correction
Pilot won't light	<ul style="list-style-type: none">■ Air in gas line■ Low gas pressure■ Gas line turned 'OFF'■ Blockage in gas line■ Pilot orifice is clogged■ Control knob not in pilot position■ Control knob not pressed in while in pilot position	<ul style="list-style-type: none">■ Purge gas line and repeat ignition operation■ Check gas pressure■ Turn 'ON' gas supply■ Check gas passage way■ Call a qualified person■ Turn control knob to pilot position■ Press in control knob while in pilot position
Igniter did not spark	<ul style="list-style-type: none">■ Igniter electrode positioned wrong■ Igniter electrode broken■ Igniter cable pinched or broken■ Igniter cable not connected to gas control	<ul style="list-style-type: none">■ Correct electrode position■ Replace electrode■ Free igniter cable, if damaged replace assembly■ Connect cable to igniter
Pilot won't stay lit	<ul style="list-style-type: none">■ Tilt switch in trip angle/OFF position■ Bad thermocouple■ Corrosion of thermocouple contact■ Safety interlock is triggered■ Bad gas valve■ Control knob not pressed in long enough■ Thermocouple connection loose at gas control or damaged■ Pilot flame not touching the thermocouple	<ul style="list-style-type: none">■ Reset the Heater keep in vertical position■ Replace thermocouple■ Clean thermocouple contact■ Wait a minute repeat ignition operation■ Replace gas valve■ After pilot lights, keep control knob pressed in for 60 seconds■ Tighten connection or replace thermocouple■ Contact a qualified service person
Main burner won't light	<ul style="list-style-type: none">■ Low gas pressure■ Blockage in burner orifice■ Control knob not in 'ON' position	<ul style="list-style-type: none">■ Check gas supply pressure■ Clean burner orifice■ Turn control knob to 'ON' position

*** * * IMPORTANT NOTICE:**
DO NOT return to place of purchase !!!
Please contact Customer Service hotline at 800-913-8999 for help

PARTS LIST

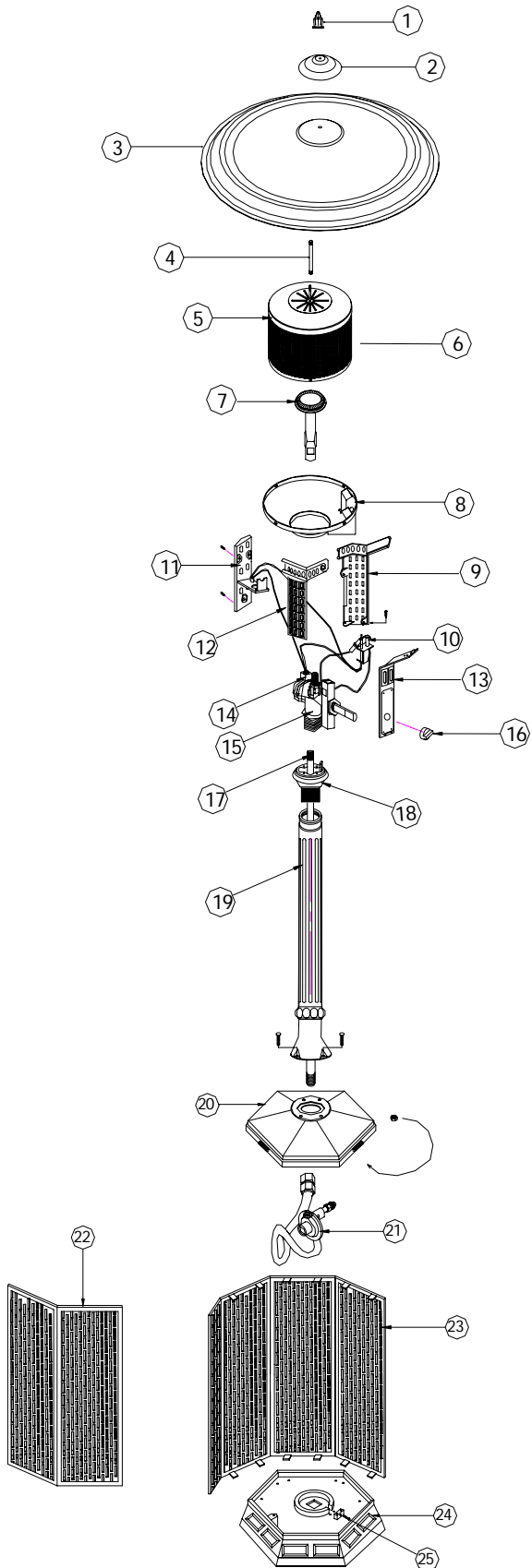

Parts List

No.	Qty	Description
1	1	Reflector Nut
2	1	Reflector Dome cap
3	1	Reflector
4	1	Threaded End Stud
5	1	Emitter Top
6	1	Emitter
7	1	Main Burner Assembly
8	1	Emitter Base
9	1	Control House Right Panel
10	1	Pilot Assembly
11	1	Control House Rear Panel
12	1	Control House Left Panel
13	1	Control House Front Panel
14	1	Orifice
15	1	Gas Valve
16	1	Control Knob
17	1	Gas Pipe
18	1	Control Housing Base
19	1	Post
20	1	Tank Cover
21	1	Regulator Assembly
22	1	Cylinder Housing Door
23	1	Cylinder Housing Panel
24	1	Weighted Base Assembly
25	1	Retention Kit

LIMITED WARRANTY

FOR MODEL PTH-105-3G

GAS-FIRED INFRARED OUTDOOR PATIO HEATER

Nexgrill warrants to the original consumer purchaser of each Outdoor Patio Heater that when subject to normal residential use, it is free from defects in workmanship and materials under normal conditions of use in a commercial application for a period of 90 days from purchase and in a residential application for a period of 1 year. Any work or repair of the heater must be performed by qualified service personal. There will be a shipping and handling charge for the delivery of the warranty part(s).

<u>Component</u>	<u>Warranty Period</u>
Burner:	3 Years
Valve:	1 Year
Pilot Kit:	1 Year
All Other Parts	1 Year

Our obligation under this warranty is limited to repair or replacement at our option of the product during the warranty period. The extent of any liability of *Nexgrill* under this warranty is limited to repair or replacement. This warranty does not cover normal wear of parts, damage resulting from any of the following: negligent use or misuse of the product, use on improper fuel/gas supply, use contrary to operating instructions, or alteration by any person other than our factory service center. The warranty period is not extended by such repair or replacement.

Warranty claim procedure: If you require service or parts for your Patio Heater, please contact our Warranty Service Center for factory direct assistance. Our hours of operation are 8 AM to 5 PM PST. Our number is 1-800-913-8999 and our FAX number is 1-909-598-7699. Please direct all correspondence to: *Nexgrill 145 Brea Canyon Road, Walnut, CA 91789 ATTN: Warranty Service Center.*

Product repair as provided under this warranty is your exclusive remedy. *Nexgrill* shall not be liable for any incidental or consequential damages for breach of any express or implied warranty on its products. Except to the extent prohibited by applicable law, any implied warranty or merchantability or fitness for a particular purpose on this product to the duration of the above warranty. Some states do not allow the exclusion or limitation of incidental or consequential damages or allow limitations on how long an implied warranty lasts, so the above limitations or exclusions may not apply to you. This warranty gives you specific legal rights, and you may have other rights which vary from state to state.