

MESSAGE TO OUR MEMBERS

Thank you for selecting our Outdoor Stainless Steel

Because this appliance contains s features not found on any other grill, we recommend that you read this entire booklet before your first use. Keep it in a handy place as it has answers to questions that may occur during future use.

Feel free to contact us if we can help you. When you write please include the model number of the grill.

We thank you for buying the stainless steel gas and wish you many years of enjoyment.

Note: This appliance is NOT intended to be installed in or on recreational vehicles or boats.

PLEASE RETAIN THIS MANUAL FOR FUTURE

TABLE OF CONTENTS

SECTION ONE:	SECTION FIVE:
Precaution -----2-3	Care and Maintenance -----14
Placement of The Grill -----3	Troubleshooting -----15
SECTION TWO:	SECTION SIX:
Assembly Instruction -----4-9	Grill Parts List-----16-17
SECTION THREE:	SECTION SEVEN:
Gas Hook-UP & Leak Testing-----10	Grill Cooking Chart -----18-20
Installer final checklist -----11	SECTION EIGHT:
Operating Instruction -----12	Grill Recipe Suggestions -----21-23
Grill lighting Instruction	
Rotisserie -----13	SECTION NINE:
SECTION FOUR:	Warranty -----24
Using The Side Burner -----13	

PRECAUTIONS

FOR YOUR SAFETY

If you smell gas:

1. Shut off gas to the appliance.
2. Extinguish any open flames.
3. Open lid.
4. If odor continues, immediately call your gas supplier.

WARNING

Do not try lighting this appliance without reading the "LIGHTING INSTRUCTIONS" section of this manual.

FOR YOUR SAFETY

Do not store or use gasoline or other flammable vapors and liquids in the vicinity of this or any other appliance.

TESTED IN ACCORDANCE WITH ANSI Z21.58a-1995 STANDARD FOR OUTDOOR COOKING GAS APPLIANCES. THIS GRILL IS FOR OUTDOOR USE ONLY.

Check your local building codes for the proper method of installation. In the absence of local codes, this unit should be installed in accordance with the National Fuel Gas Code No. Z223.1-1988 and the National Electrical Code ANSI/NFPA No. 70-1990.

CALIFORNIA PROPOSITION 65- WARNING

The burning of gas fuel generates some byproducts, which are on the list of substances which are known by the State of California to cause cancer or reproductive harm. California law requires businesses to warn customers of potential exposure to such substances. To minimize exposure to these substances, always operate this unit according to the use and care manual, ensuring you provide good ventilation when cooking with gas.

SAFETY PRACTICES TO AVOID PERSONAL INJURY

When properly cared for, your 720-0070 Grill will give safe, reliable service for many years. However, extreme care must be used since the grill produces

intense heat and can increase accident potential. When using this appliance basic safety practices must be followed, including the following:

Read this Care and Use Manual carefully and completely before using your grill to reduce the risk of fire, burn hazard or other injury.

Begin by ensuring proper assembly.

Do not repair or replace any part of the grill unless specifically recommended in this manual. All other service should be referred to a qualified technician.

CHILDREN SHOULD NOT BE LEFT ALONE OR UNATTENDED IN AN AREA WHERE THE GRILL IS BEING USED. NEVER ALLOW THEM TO SIT, STAND OR PLAY ON OR AROUND THE GRILL AT ANY TIME.

DO NOT STORE ITEMS OF INTEREST TO CHILDREN AROUND OR BELOW THE GRILL OR IN THE CART. NEVER ALLOW CHILDREN TO CRAWL INSIDE OF THE CART.

Never let clothing, pot holders or other flammable materials come in contact with or too close to any grate, burner or hot surface until it has cooled. Fabric may ignite and result in personal injury.

For personal safety, wear proper apparel. Loose fitting garments or sleeves should never be worn while using this appliance. Some synthetic fabrics are highly flammable and should not be worn while cooking.

Only certain types of glass, heat-proof glass ceramic, earthenware, or other glazed utensils are suitable for grill use. These types of materials may break with sudden temperature changes. Use only on low or medium heat settings according to the manufacturer's directions.

Do not heat unopened food containers as a build-up of pressure may cause the container to burst.

Use a covered hand when opening the grill lid. Never lean over an open grill.

WHEN LIGHTING A BURNER, ALWAYS PAY CLOSE ATTENTION TO WHAT YOU ARE DOING. BE CERTAIN YOU ARE TURNING THE IGNITER LABELED FOR THE BURNER YOU INTEND ON USING.

PRECAUTIONS

When using the grill, do not touch the grill rack, burner grate or immediate surrounding area as these areas become extremely hot and could cause burns. Use only dry potholders. Moist or damp potholders on hot surfaces may cause burns from steam. Do not use a towel or bulky cloth in place of potholders. Do not let potholders touch hot portions of the grill rack.

Grease is flammable. Let hot grease cool before attempting to handle it. Avoid letting grease deposits collect in the bottom of the grill. Clean often.

DO NOT USE ALUMINUM FOIL TO LINE THE GRILL RACKS OR GRILL BOTTOM. This can severely upset combustion air flow or trap excessive heat in the control area. The result of this can be melted knobs, rotary igniters and increased chance of personal injury.

For proper lighting and performance of the burners keep the ports clean. It is necessary to clean them periodically for optimum performance. The burners will only operate in one position and must be mounted correctly for safe operation.

Clean the grill with caution. Avoid steam burns; do not use a wet sponge or cloth to clean the grill while it is hot. Some cleaners produce noxious fumes or can ignite if applied to a hot surface.

INSECT WARNING!!! Spiders and insects can nest in the burners of this and any other grill, and cause the gas to flow from the front of the burner. This is a very dangerous condition which can cause a fire to occur behind the value panel, thereby damaging the grill and making it unsafe to operate. Inspect the grill twice a year.

Be sure all grill controls are turned off and the grill is cool before using any type of aerosol cleaner on or

around the grill. The chemical that produces the spraying action could, in the presence of heat, ignite or cause metal parts to corrode.

Do not use the grill for cooking excessively fatty meats or products which promote flare-ups. Do not operate the grill under unprotected combustible construction. Use only in well ventilated areas. Do not use in buildings, garages, sheds, breezeways or other such enclosed areas. **THIS UNIT IS FOR OUTDOOR USE ONLY.**

Keep the area surrounding the grill free from combustible materials, trash, or combustible fluids and vapors such as gasoline or charcoal lighter fluid. Do not obstruct the flow of combustion and ventilation air. If the unit is stored indoors ensure that it is cool. If propane is used, the cylinder must be unhooked and the propane cylinder stored outside in a well ventilated area, out of reach of children.

DO NOT USE BRIQUETTES OF ANY KIND IN THE GRILL.

The VII stainless steel gas is designed for optimum performance without the use of briquettes. Do not place briquettes on the radiant as this will block off the area for the grill burners to vent. Adding briquettes can damage ignition components and knobs, and void the warranty. Keep the back of the cart free and clear from debris. Keep any electrical supply cord, or the rotisserie motor cord away from the heated areas of the grill.

Never use the grill in windy conditions. If located in a consistently windy area (oceanfront, mountaintop, etc.) a windbreak will be required. Always adhere to the specified clearance.

NEVER USE A DENTED OR RUSTY PROPAN

PLACEMENT OF THE GRILL

CLEARANCE

To Non-Combustible Construction

A minimum of 3" clearance from the back of the grill to non-combustible construction is required for the lid to open fully.

DO NOT INSTALL THIS UNIT INTO COMBUSTIBLE ENCLOSURES!

LOCATION



When determining a suitable location take into account concerns such as exposure to wind, proximity to traffic paths and keeping any gas supply lines as short as possible. Locate the grill only in a well-ventilated area. Never locate the grill in a building, garage, breezeway, shed or other such enclosed areas without an approved ventilation system. During heavy use, the grill will produce a lot of smoke. Lock the wheels after the grill is placed in a suitable position according to the sticker located beneath the right door.

Assemble Instructions

PLEASE READ THE INSTRUCTIONS CAREFULLY AND FOLLOW STEP BY STEP.

TOOLS REQUIRED:

Philips head screwdriver (not provided), wrench (provided), Allen key (provided). The following hardware is provided.

Item	Description	Specification	Quantity
1	Truss head screw 	1/4-20*1-1/2 inch	12pcs
2	Truss head screw 	1/4-20*1/2 inch	18pcs

Step 1:

Remove side panel (marked "L") and two 3" casters from the carton . Put two casters and side panel marked "L" together with provided wrench. Repeat this figure for the right side panel.

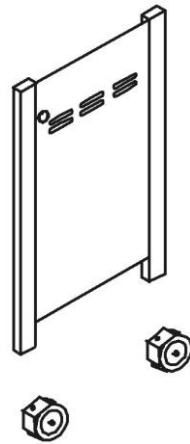

Step 2:

Assemble bottom panel to side panels with 8 pieces of Truss Head 1/4-20 x 1-1/2" screws. Follow the mark "L" and "R" accordingly.

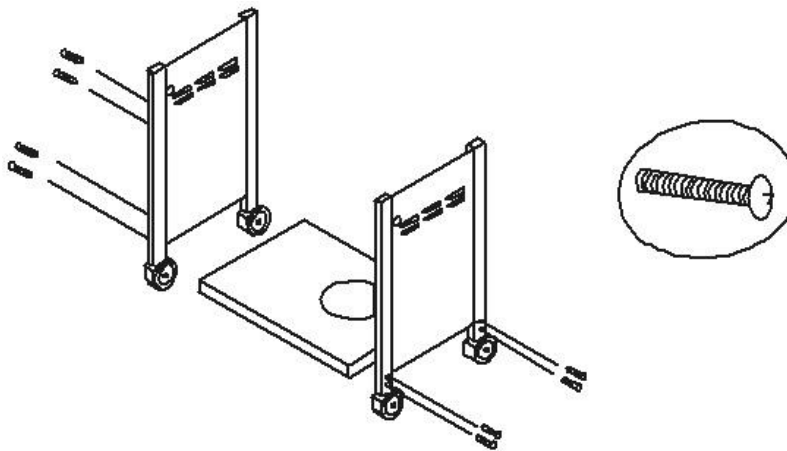

Truss Head 1/4" -20×1 1/2" Screw

Step 3:

Align the 2 doors with the bottom panel holes first & align with the door bracket & then with top of the 2 side panels, use the four pieces 1/4"-20X1 1/2" screws for the both side panels.

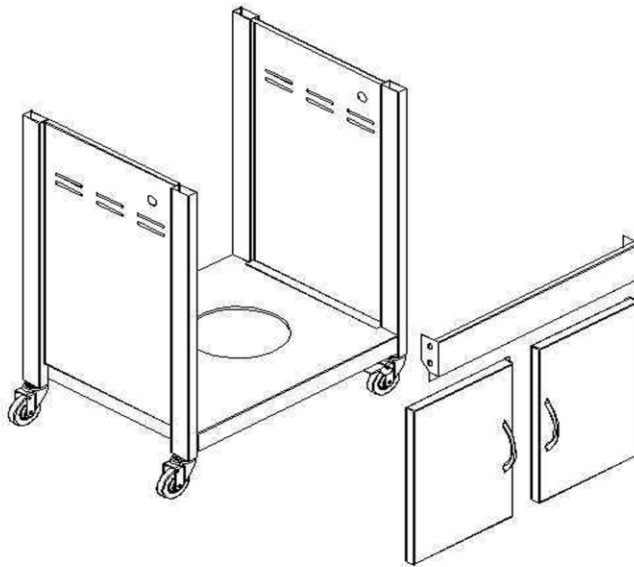

Step 4:

Remove the upper portion of grill from carton "A". Slide-in the upper portion of the grill onto the cart as shown below.

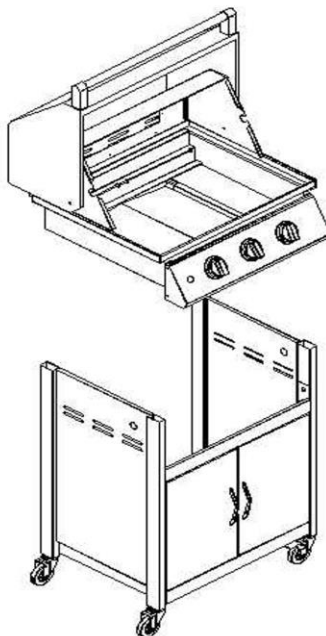

Step 5:

Screw the upper portion of the grill to the cart with Truss head 1/4-20 x 1/2". Screw in 4 corners of the grill housing. Make sure 4 screws are tight.

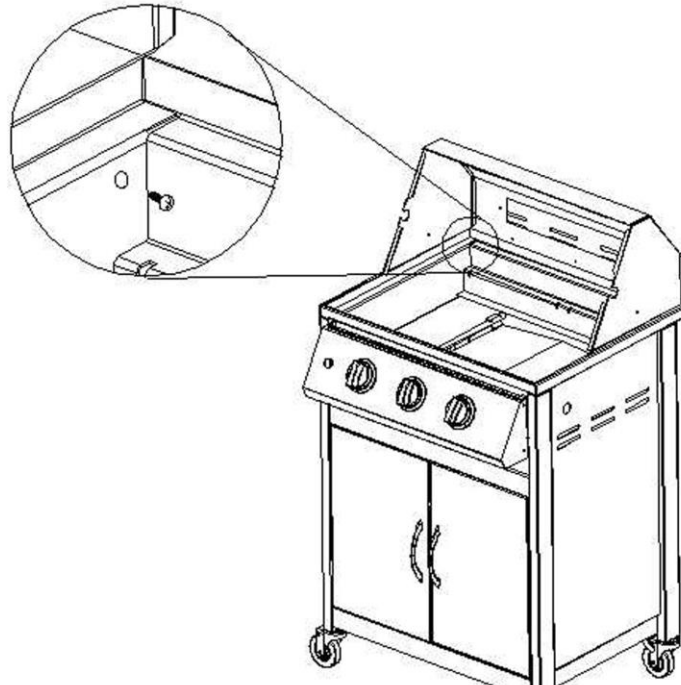

Step 6:

Assemble the back pan

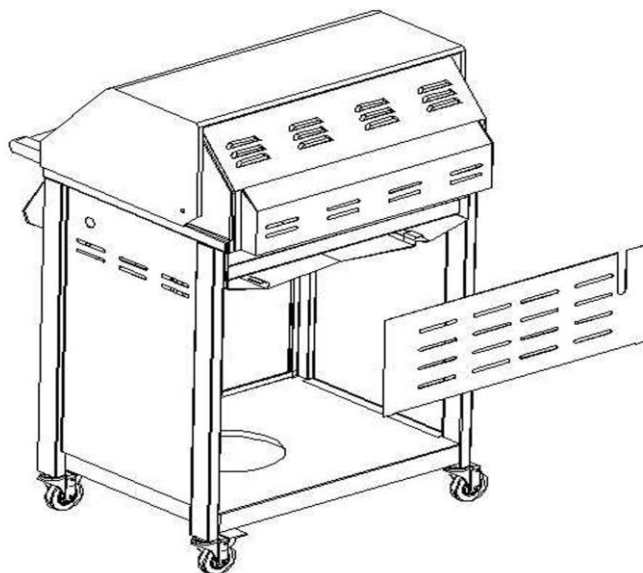

Truss Head Screw 1/4-20*1/2"

Step 7:

Assemble side burner with 1/4-20 x 1/2" screws. Align the holes on the right side of grill housing and screw through the holes in the side burner grate and tighten into the grill housing as per the diagram below. Repeat this step for the side shelf.

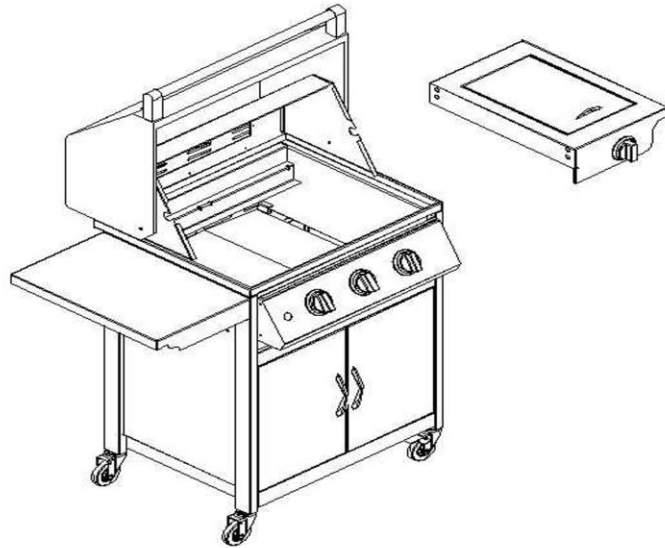

Step 8:

Place two flame tamers, cooking grids, warming rack and grease tray as shown below.

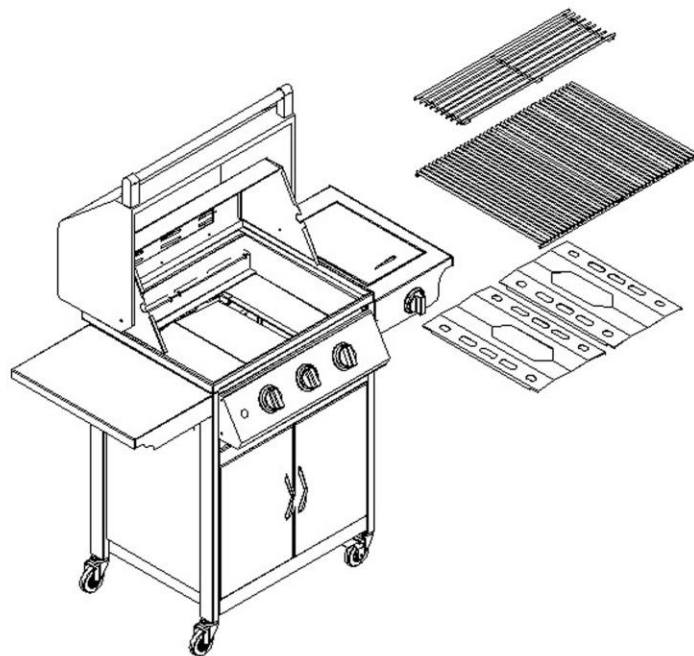

Step 9:

Assemble the rotisserie kit as per the diagram below First locate the motor bracket on left side of the bowl assembly with two “1/4-20 x 1/2” truss head screws. Then place the Motor onto the motor bracket and last assemble the rotisserie as the figure shows.

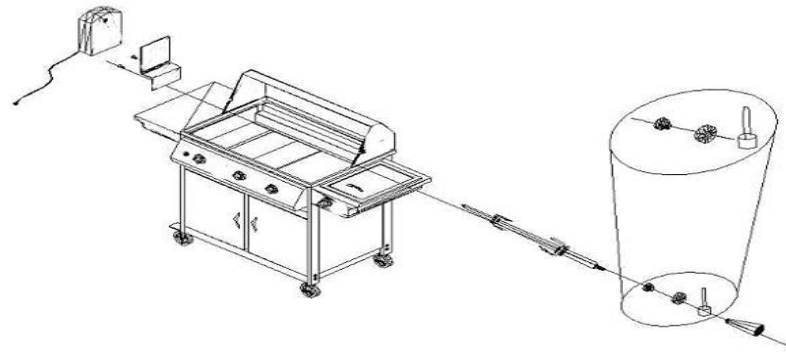

Step 10:

To install the battery, turn the ignition button housing counterclockwise and remove it. The rotisserie burner ignition switch uses an AAA size battery. Please keep the positive pole facing toward you . Replace the ignition button housing after batteries are installed.

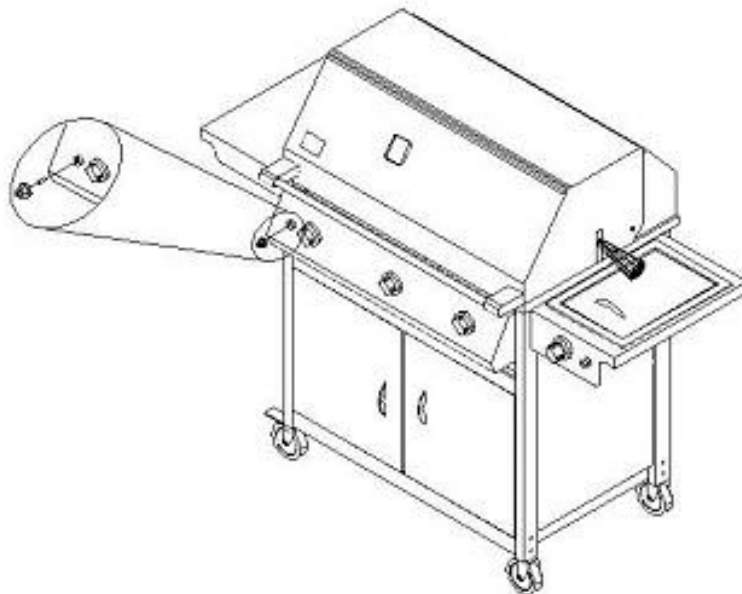

Your gas grill is ready to use.

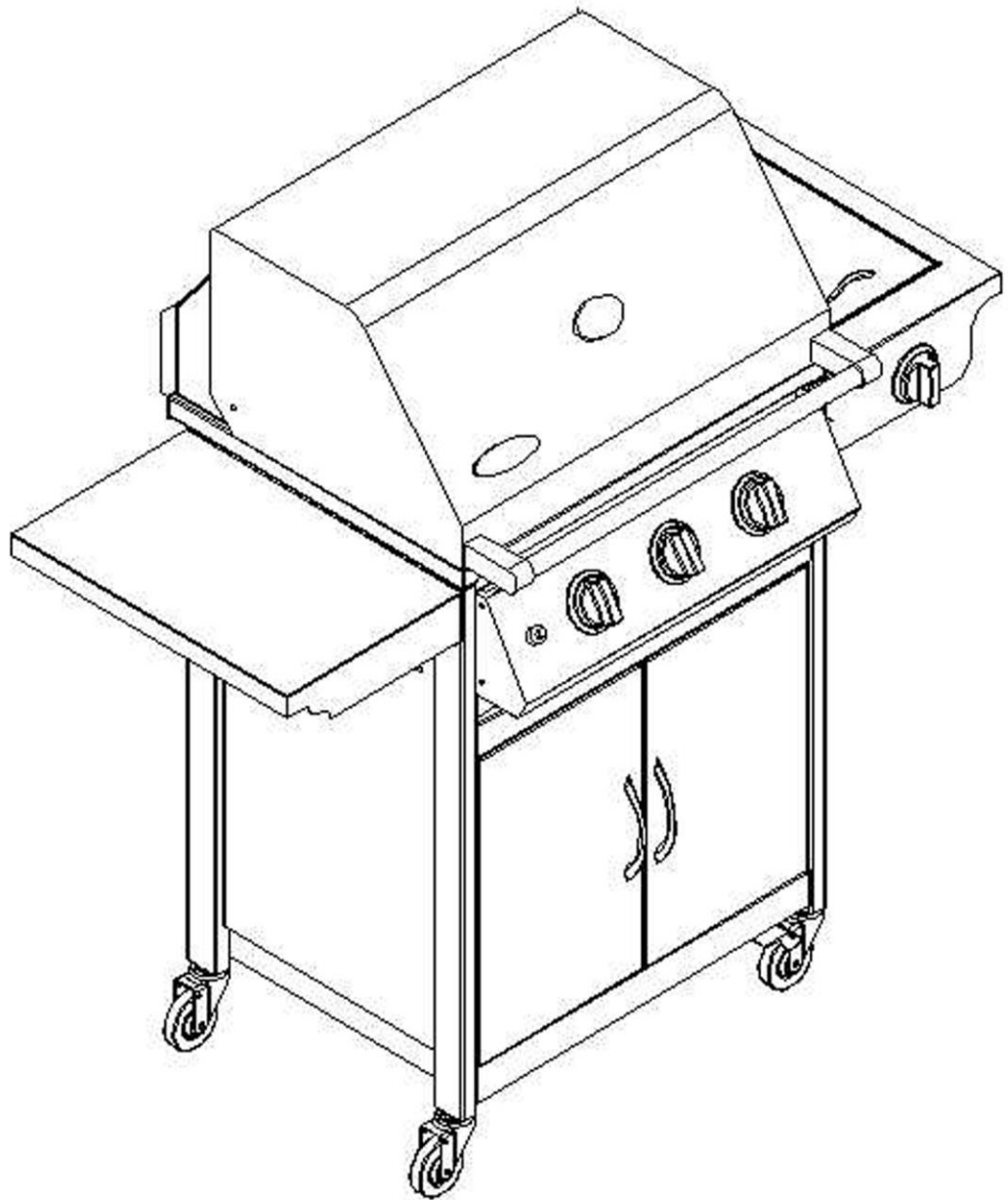

GAS HOOK-UP

NEVER CONNECT AN UNREGULATED GAS SUPPLY LINE TO THE APPLIANCE. USE THE REGULATOR ASSEMBLY SUPPLIED.

This is a liquid propane configured grill. Do not attempt to use a natural gas supply unless the grill has been reconfigured for natural gas use.

Total gas consumption (per hour) of The outdoor stainless steel gas with all burners on "HI":

Main burners	30,000 Btu/hr.
Rotisserie burner	10,000 Btu/hr.
Side burner	12,000 Btu/hr.
Total	52,000 Btu/hr.

The installation of this appliance must conform with local codes or, in the absence of local codes, with the national fuel gas code, ANSI Z223.1a-1988. Installation in Canada must be in accordance with the Standard Can1-b149.1 and/or .2 (installation code for gas burning appliances and equipment) and local codes.

L.P. Tank Requirements

A dented or rusty L.P. tank may be hazardous and should be checked by your L.P. supplier. Never use a cylinder with a damaged valve. The L.P. gas cylinder must be constructed and marked in accordance with the specifications for L.P. gas cylinders of the U.S. Department of Transportation (DOT). The cylinder must be provided with a shut off valve terminating in an L.P. gas supply cylinder valve outlet specified, as applicable, for connection type QCC1 in the standard for compressed gas cylinder valve outlet and inlet connection ANSI/CGA-V-1.

Manifold pressure: (operating): 10" water column (W.C.), (non-operating): 11.2" water column (W.C.).

L.P. GAS HOOK-UP:

Ensure that the black plastic grommets are in place and that the hose does not come into contact with the heat shield or the grill head.

CONNECTION:

Orifices for use with L.P. gas come equipped with a high capacity hose/regulator assembly for connection to a standard 20lb. L.P. cylinder (18-1/4" high, 12-1/4" diameter).

To connect the L.P. gas supply cylinder, please follow the steps below:

1. Make sure tank valve is in its full off position (turn clockwise to stop)
2. Check tank valve to assure it has proper external male threads (type 1 connection per ANSIZ21.81)
3. Make sure all burner valves are in their off position.
4. Inspect valve connections port and regulator assembly. Look for any damage or debris. Remove any debris. Inspect hose for damage. Never attempt to use damaged or plugged equipment. See your local L.P. gas dealer for repair.
5. When connecting regulator assembly to the valve, hand tighten nut clockwise to a positive stop. Do not use a wrench to tighten. Use of a wrench may damage quick coupling nut and result in a hazardous condition.
6. Open tank valve fully (counterclockwise). Use a soapy water solution to check all connections for leaks before attempting to light grill. If a leak is found, turn tank valve off and do not use grill until a local L.P. gas dealer can make repairs.

To disconnect L.P. gas cylinder:

1. Turn the burner valve off.
2. Turn the tank valve off fully (turn clockwise to stop).
3. Detach the regulator assembly from tank valve by turning the quick coupling nut counterclockwise.

LEAK TESTING

GENERAL

Although all gas connections on the grill are leak tested at the factory prior to shipment, a complete gas tightness check must be performed at the installation site due to possible mishandling in shipment, or excessive pressure unknowingly being applied to the unit. Periodically check the whole system for leaks, or immediately check if the smell of gas is detected.

BEFORE TESTING

Make sure that all packing material is removed from the grill including the burner tie-down straps.

DO NOT SMOKE WHILE LEAK TESTING.

NEVER LEAK TEST WITH AN OPEN FLAME.

Make a soap solution of one part liquid detergent and one part water. You will need a spray bottle, brush, or rag to apply the solution to the fittings. For the initial leak test, make sure the L.P. cylinder is full.

TO TEST

Make sure all control valves are in the “OFF” position. Turn the gas supply on. Check all connections from the L.P. cylinder up to and including the connection to the manifold pipe assembly (the pipe that goes to the burner). Soap bubbles will appear where a leak is present. If a leak is present, immediately turn off gas supply, tighten any leaking fittings, turn gas on, and recheck. Should the gas continue to leak from any or all of the fittings, turn off the gas supply, and contact our customer service at 1-800-913-8999.

Only those parts recommended by the manufacturer should be used on the grill. Substitution can void the warranty. Do not use the grill until all connections have been checked and do not leak.

ALWAYS CHECK FOR LEAKS AFTER EVERY L.P. TANK CHANGE

Check all gas supply fittings for leaks before each use. It is handy to keep a spray bottle of soapy water near the shut-off valve of the gas supply line. Spray all the fittings. Bubbles indicate leaks.

Disconnected L.P. cylinders must have threaded valve plugs tightly installed, and must not be stored in a building, garage or any other enclosed area.

The gas must be turned off at the supply cylinder when the unit is not in use.

If the appliance is stored indoors the cylinder must be disconnected and removed from the appliance. Cylinders must be stored outdoors in a well-ventilated area out of the reach of children.

Gas flow check:

Each grill burner is tested and adjusted at the factory prior to shipment; however, variations in the local gas supply may make it necessary to adjust the burners. The flames of the burners should be visually checked.

Flames should be blue and stable with no yellow tips, excessive noise or lifting. If any of these conditions exist, check if the air shutter or burner ports are blocked by dirt, debris, spider webs, etc.

INSTALLER FINAL CHECK LIST

- Specified clearance maintained 24” from combustibles.
- All internal packaging removed.
- Knobs turn freely.
- Burners are sitting properly on orifices.
- Pressure regulator connected and set for 11.2” W.C. L.P. gas. Gas connections to grill using hose & regulator assembly provided (pre-set for 11.0” water column).
- Unit tested and free of leaks.
- User informed of gas supply shut off valve location.

USER, PLEASE RETAIN THESE INSTRUCTIONS FOR FUTURE REFERENCE.

OPERATING INSTRUCTION

General use of the grill and rotisserie

Each burner is rated at 15,000 Btu/hr. The grill burners encompass the entire cooking area and are side ported to minimize blockage from falling grease and debris. Above the burners are stainless steel radiants. The igniter knobs are located on the lower center portion of the valve panel. Each rotary igniter is labeled on the Lighting Instructions Plate.

USING THE GRILL:

Grilling requires high heat for searing and proper browning. Most foods are cooked at the “HI” heat setting for the entire cooking time. However, when grilling large pieces of meat or poultry, it may be necessary to turn the heat to a lower setting after the initial browning. This cooks the food through without burning the outside. Foods cooked for a long time or basted with a sugary marinade may need a lower heat setting near the end of the cooking time.

Make sure the grill has been leak tested and is properly located.

Remove any packing material.

Light the grill burners using the instructions in this manual.

Turn the control knob to “HI” and preheat the grill for 15 minutes. The grill lid is to be closed during the appliance preheat period.

Place the food on the grill and cook to the desired doneness. Adjust heat setting, if necessary. The control knob may be set to any position between “HI” and “LO”.

NOTE: The outdoor stainless steel gases designed to grill efficiently without the use of lava rocks or briquettes of any kind. Heat is radiated by the stainless steel flame tamers positioned beneath the solid stainless steel rods.

NOTE: The hot grill sears the food, sealing in the juices. The longer the preheat, the faster the meat browns and the darker the grill marks.

DO NOT LEAVE THE GRILL UNATTENDED WHILE COOKING.

USING ROTIS BURNER:

Your grill is capable of performing back burner rotis cooking. Light the rear burner as described in the lighting instructions. Once lit, the rotis burner will reach cooking temperatures in about 1 minute.

The rotis motor is capable of turning up to a 12lb. cut of meat or poultry. The motor slides onto the metal motor

mount. The rotisserie motor must be electrically grounded in accordance with local codes or, in the absence of local codes, with the National Electrical Code, ANSI/NFPA 70-1990.

The skewer for the rotis is assembled into the motor assembly by placing the pointed end into the motor, and resting the grooved bushing on the support at the opposite side of the grill. The thumbscrew should be inside the grill body. With the skewer pushed as far as possible into the motor, the skewer should rest on the left side of the grill body. To load the skewer begin with the handle in place, and slide one of the meat forks (prongs toward the food) onto the skewer. Center the product to be cooked on the skewer then push the meat forks firmly together. Tighten the wing nuts as tight as possible.

It may also be necessary to wrap the food with butchers string (never use nylon or plastic string) to secure any loose portions. Once the food is secure insert the skewer into the motor. It is normal for the skewer to flex when larger cuts of meat are being cooked. It may also be necessary to remove the grill rods for larger cuts of meat. If the meat scrapes on the grill rods during any part of the rotation, then the grill rods must be removed. Assemble the counterweight with washers and handle to counter balance the heaviest side of the meat. By using the counterweight the rotisserie motor should turn smoothly through all 360 degrees of rotation.

After your first use of the rotis burner it is likely that the stainless steel adjacent to the burner will darken to a dark blue color. This is a normal property of the non-rusting, type 304 stainless steel used on the grill.

CAUTION: PLEASE TAKE OFF THE WARMING RACK WHEN USING THE ROTIS BURNER. THE HIGH HEAT COMING FROM THE ROTIS BURNER MAY CAUSE THE WARMING RACK TO BEND.

WARNING
ELECTRICAL GROUNDING INSTRUCTIONS. This appliance (rotisserie motor) is equipped with a plug and should be plugged directly into a properly grounded receptacle. **DO NOT** cut or remove the grounding prong from this plug.

Keep the rotis motor electric cord away from the heated surfaces of the grill. When not in use remove and store the motor in a dry location.

LIGHTING INSTRUCTIONS GRILL/ROTIS

WARNING: IMPORTANT!

BEFORE LIGHTING...

Inspect the gas supply piping or hose prior to turning the gas "ON". If there is evidence of cuts, wear, or abrasion, it must be replaced prior to use. Do not use the grill if the odor of gas is present. The pressure regulator and hose assembly supplied with the unit must be used. Never substitute regulators for those supplied with the grill. If a replacement is necessary, contact the factory for proper replacement.

Screw the regulator (type QCC1) onto the tank. Leak check the hose and regulator connections with a soap and water solution before operating the grill (see assembly instruction).

TO LIGHT THE GRILL BURNER:

Turn all knobs to "OFF" then turn on the gas supply. Always keep your face and body as far from the grill as possible when lighting.

Open the lid, push and turn one control knob to the "HI" position and press the electric igniter for 3 to 4 seconds to light the burner. If the burner does not light, wait for 5 minutes then retry.

TO MATCH LIGHT THE GRILL:

If the burner will not light after several attempts then the burner can be match lit.

If you've just attempted to light the burner with the igniter, allow 5 minutes for any accumulated gas to dissipate. Keep your face and hands as far away from the grill as possible. Insert a lit extended match or lighter through the cooking grids to the burner. Press the control knob and rotate left to the HI setting which should release the gas. Burner will light immediately.

Push and turn the control knob which is centered on the burner to "HI". If the burner does not light in 4 seconds turn the knob off, wait 5 minutes and try again.

TO LIGHT THE ROTIS BURNER:

Open the lid, push and turn the control knob to the "HI" position. Press the electric igniter for 3 to 4 seconds to light the burner. If the burner does not light within 4 seconds, turn the control knob to "OFF". If the igniter does not function, the burner can be lit by holding a lit match to the burner (with the control knob at "HI").

Keep a spray bottle of soapy water near the gas supply valve and check the connections before each use.

Do not attempt to light the grill if odor of gas is present. Call for service 1-800-913-8999.

USING THE SIDE BURNER

WARNING: IMPORTANT!

USING THE SIDE BURNER:

Inspect the gas supply piping or hose prior to turning the gas "ON". If there is evidence of cuts, wear or abrasion, it must be replaced prior to use. Do not use the side burner if the odor of gas is present.

WARNING: *Always keep your face and body as far away from the burner as possible when lighting.*

LIGHTING INSTRUCTIONS

To light side burner, remove any cooking utensils from the burner grate. Push and turn the control knob counterclockwise to the "HI" position. This will start the gas flowing. Press the electric igniter for 3 to 4 seconds to light the burner. If the burner does not light within 4 seconds, turn the control knob to "OFF". If the smell of gas is detected and the igniter is not functioning, immediately turn the control knob "OFF". Allow 5 minutes for any accumulated gas to dissipate, then see the following section for "MATCH LIGHTING".

MATCH LIGHTING

Hold a lit extended match or lighter near the burner ports, turn the control knob counterclockwise to "HI". Move your hand immediately once the burner is lit. Rotate the control knob to the desired setting. Check for proper burner flame characteristics. Each burner is adjusted prior to shipment; however, variations in the local gas supply may take minor adjustments necessary.

Burner flames should be blue and stable with no yellow tips, excessive noise, or lifting. If any of these conditions exist call our customer service line. If the flame is yellow, it indicates insufficient air. If the flame is noisy and tends to lift away from the burner, it indicates too much air.

STAINLESS STEEL

The grill is made from non-rusting and non-magnetic stainless steel. There are many different stainless steel cleaners available. Always use the mildest cleaning

procedure first, scrubbing in the direction of the grain. To touch up noticeable scratches in the stainless steel, sand very lightly with dry 100 grit emery paper in the direction of the grain. Specks of grease can gather on the surfaces of the stainless steel and bake on to the surface and give the appearance of rust. For removal use an abrasive pad in conjunction with a stainless steel cleaner.

GRILL RACK

The easiest way to clean the grill is immediately after cooking is completed and after turning off the flame. Wear a barbeque mitt to protect your hand from the heat and steam. Dip a brass bristle barbeque brush in tap water and scrub the hot grill. Dip the brush frequently in the bowl of water. Steam, created as water contacts the hot grill, assists the cleaning process by softening any food particles. The food particles will fall and burn. If the grill is allowed to cool before cleaning, cleaning will be more difficult.

CARE & MAINTENANCE OF SIDE BURNER

ENSURE THAT THE GAS SUPPLY AND THE KNOBS ARE IN THE "OFF" POSITION. MAKE SURE THE RANGETOP BURNER IS COOL BEFORE REMOVAL.

BURNER CLEANING:

Clean the exterior of the burner with a wire brush. Clear any clogged burner ports with a straightened paper clip. Never enlarge the burner ports. Never use a wooden toothpick as it may break off the clog the port.

GREASE TRAY CLEANING:

The grease tray should be emptied and wiped down periodically and washed in a mild detergent and warm water solution. A small amount of sand or cat litter may be placed in bottom of grease tray to absorb the grease.

GRILL BURNERS

Extreme care should be taken when moving a burner as it must be correctly centered on the orifice before any attempt is made to relight the grill. Frequency of cleaning will depend on how often you use the grill.

GRILL BURNER CLEANING

Ensure the gas supply is off and the knobs are in the "OFF" position. Make sure the grill is cool. Clean the exterior of the burner with a wire brush. Clear stubborn scale with a metal scraper. Clear any clogged ports with a straightened paper clip. Never use a wooden toothpick as it may break off and clog the port. Please note if insects or other obstructions are blocking the flow of gas through the burner, you will need to call our customer service line.

STAINLESS STEEL:

There are many different stainless steel cleaners available. Always use the mildest cleaning procedure first, scrubbing in the direction of the grain. Do not use steel wool as it will scratch the surface. To touch up noticeable scratches in the stainless steel, sand very lightly with dry 100 grit emery paper in the direction of the grain.

TOP BURNER GRATE:

The top burner grate is stainless steel. To avoid burns do not clean a hot grate. They may be wiped while in place with hot, soapy water, rinsed and wiped dry. Never immerse a hot grate in water

CLEANING THE S.S COMPONENTS

ENSURE THAT THE GAS SUPPLY AND THE KNOBS ARE IN THE "OFF" POSITION. MAKE SURE THE RANGETOP BURNER IS COOL BEFORE REMOVAL.

BURNER CLEANING:

Clean the exterior of the burner with a wire brush. Clear any clogged burner ports with a straightened paper clip. Never enlarge the burner ports. Never use a wooden toothpick as it may break off the clog the port.

GREASE TRAY CLEANING:

The grease tray should be emptied and wiped down periodically and washed in a mild detergent and warm

water solution. A small amount of sand or cat litter may be placed in bottom of grease tray to absorb the grease.

STAINLESS STEEL:

There are many different stainless steel cleaners available. Always use the mildest cleaning procedure first, scrubbing in the direction of the grain. Do not use steel wool as it will scratch the surface. To touch up noticeable scratches in the stainless steel, sand very lightly with dry 100 grit emery paper in the direction of the grain.

TROUBLE SHOOTING

SPIDER AND INSECT WARNING!!!

Spiders and insects can nest in the burners of this or any other grill, and cause the gas to flow from the front of the burner. This is very dangerous condition which can cause a fire to occur behind the valve panel, thereby damaging the grill and making it unsafe to operate.

WHEN TO LOOK FOR SPIDERS

You should inspect the burners at least once a year or immediately if any of the following conditions occur:

1. The smell of gas in conjunction with the burner flames appearing yellow.
2. The grill does not reach temperature.
3. The grill heats unevenly.
4. The burners make popping noises.

BEFORE CALLING FOR SERVICE

If the grill does not function properly, use the following checklist before contacting your dealer for service. You may save the cost of a service call.

CHECK LIST

PROBLEMS	WHAT TO DO
Grill won't light when the ignition button is pushed.	Remove the grill rack and the radiant tray. With a mirror, watch the igniter tip. You should see a spark jump from the tip of the igniter when the button is pressed. You should also hear a repeating click.
	If there is no spark and no click, replace the battery under the ignition button housing. If you replace the battery and there is still no sparks, can you match light the burner? If the burner lights with a match, you can continue operating the grill, but you will need to call our customer service line to repair the electronic ignition. If the burner will not light by the match, please check the other burners to see if they will operate. If gas is blocked to 1 or more burners call our customer service for advise. Please also check the igniter tip to see if it is clean and free from debris. You can sand this area lightly and readjust it for 3/16" gap.
	Do other burners on the unit operate?
	Check the orifice for blockage.
Burner flame is yellow or orange, in conjunction with the odor of gas.	Call our customer service line.
Low heat with knob in "HI" position.	Is the fuel hose bent or kinked?
	Is the grill in a dusty area?
	Is there adequate gas supply available? If it is only one burner that appears low, does the orifice or burner need cleaning?
	Is the gas supply, or gas pressure low?
	Is the grill being preheated for 15 minutes?

Parts List

ILLUSTRATED PARTS BREAKDOWN Model 720-0070 LP Outdoor Gas Grill

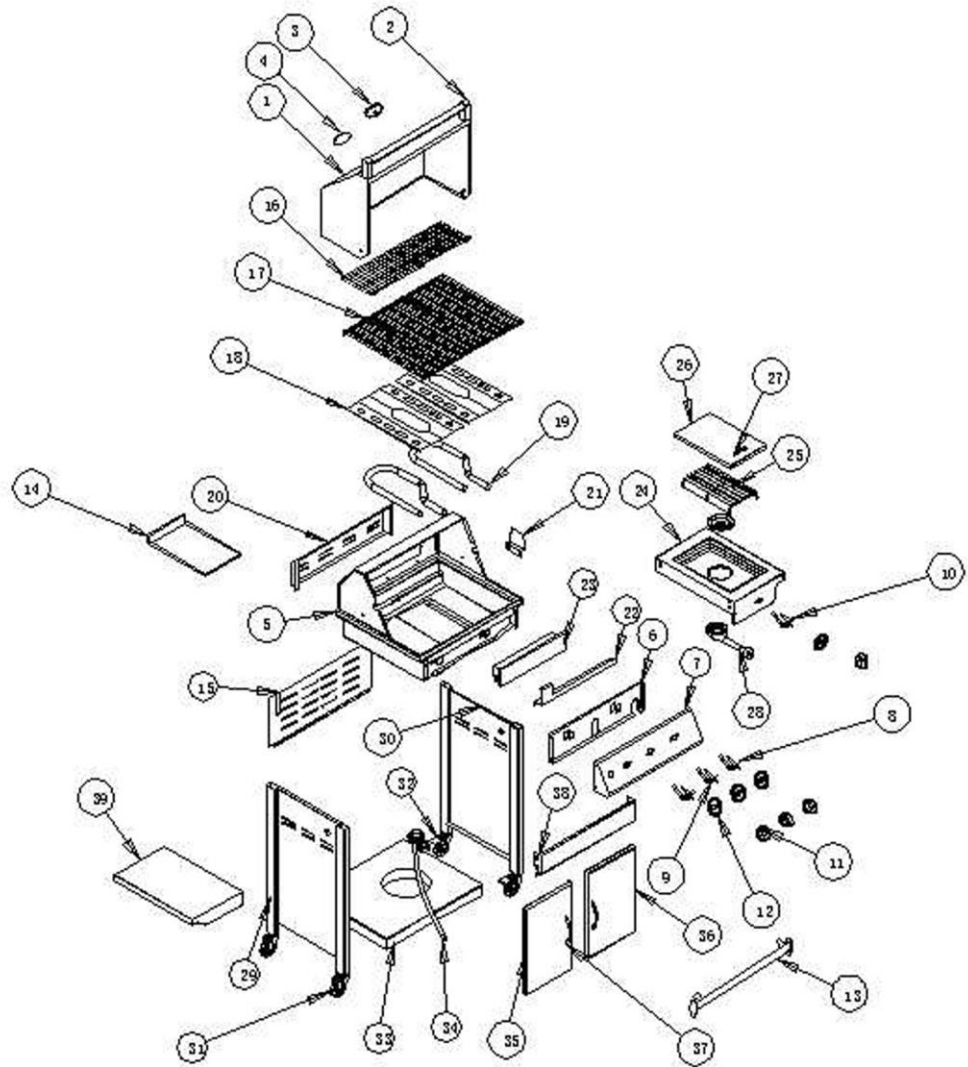

MODEL 720-0070 PARTS LIST

REF#	DESCRIPTION	QTY	PART#	REF#	DESCRIPTION	QTY	PART#
1	FRONT LID	1PIECE	BBQ001	24	SIDE BURNER BODY	3PIECES	BBQ024
2	HANDLE,FRONT LID	1PIECE	BBQ002	25	WARMING RACK,SIDE BURNER	2PIECES	BBQ025
3	THERMOMETER	1PIECE	BBQ003	26	LID,SIDE BURNER	1PIECE	BBQ026
4	LOGO	1PIECE	BBQ004	27	HANDLE,SIDE BURNER	1PIECE	BBQ027
5	BOWL ASSEMBLY	1PIECE	BBQ005	28	CAST IRON SIDE BURNER	2PIECES	BBQ028
6	FRONT BAFFLE	1PIECE	BBQ006	29	SIDE PANEL,LEFT	2PIECES	BBQ029
7	CONTROL PANEL	1PIECE	BBQ007	30	SIDE PANEL,RIGHT	1PIECE	BBQ030
8	MAIN BURNER VALVE	1PIECE	BBQ008	31	CASTER	1PIECE	BBQ031
9	REAR BURNER VALVE	1PIECE	BBQ009	32	CASTER WITH BRAKE	1PIECE	BBQ032
10	SIDE BURNER VALVE	1PIECE	BBQ010	33	BOTTOM PANEL	1PIECE	BBQ033
11	KNOB	1PIECE	BBQ011	34	REGULATOR	1PIECE	BBQ034
12	BEZEL	1PIECE	BBQ012	35	LEFT OPEN DOOR	1PIECE	BBQ035
13	MANIFOLD	2PIECES	BBQ013	36	RIGHT OPEN DOOR	1PIECE	BBQ036
14	GREASE TRAY	1PIECE	BBQ014	37	HANDLE,OPEN DOOR	1PIECE	BBQ037
15	REAR PANEL	1PIECE	BBQ015	38	DOOR BRACKET	3PIECES	BBQ038
16	WARMING RACK	1PIECE	BBQ016				
17	COOKING GRID	3PIECES	BBQ017				
18	FLAME TAMER	3PIECES	BBQ018				
19	MAIN BURNER	1PIECE	BBQ019				
20	REAR BAFFLE,REAR BURNER	3PIECES	BBQ020				
21	MOTOR BRACKET	2PIECES	BBQ021				
22	GAS COLLECTOR,REAR BURNER	3PIECES	BBQ022				
23	REAR BURNER	2PIECES	BBQ023				

To make sure you obtain the correct replacement part(s) for your gas grill, please refer to the parts list on this page. The following information is required to assure getting the correct part.

- Gas grill model number (see data sticker on grill).
- Part number of replacement part needed.
- Description of replacement part needed.
- Quantity of parts needed.

To obtain replacement parts, contact the dealer from which products was purchased. If dealer service is not available, contact: Virco Associates, Inc. Customer service 1-800-913-8999 or fax 909-598-7699.

IMPORTANT

Use only factory authorized parts. The use of any part that is not factory authorized can be dangerous. This will also void your warranty.

Keep this assembly and operating instruction manual for convenient referral, and for replacement parts ordering.

CAUTION:

Gas valves are present at the factory (valve assembly will be marked accordingly). If you wish to convert at some later date, be sure to contact your gas supplier or grill dealer before making the conversion.

A different gas valve must be installed when converting from one type of gas to another. You will also need a data plate indicating what type of gas is used by the grill.

GRILL COOKING CHART

FOOD	WEIGHT OR THICKNESS	FLAME SIZE	APPROXIMATE TIME	SPECIAL INSTRUCTIONS AND TIPS
VEGETABLES				
Fresh				Slice. Dot with butter or margarine. Wrap in heavy-duty foil. Grill, turning occasionally.
Beets		Medium	12 to 20 minutes	
Carrots				
Turnips				Grill, turning once. Brush occasionally with melted butter or margarine.
Onion	1/2 inch slices	Medium	8 to 20 minutes	
Potatoes				Wrap individually in heavy-duty foil. Grill, rotating occasionally.
Sweet	Whole	Medium	40 to 60 minutes	
White	6 to 8 ounces	High	45 to 60 minutes	
Frozen				Dot with butter or margarine. Wrap in heavy-duty foil. Grill, turning occasionally.
Asparagus		Medium	15 to 30 minutes	
Broccoli				
Brussels				
Sprouts				
Green beans				
Peas				
French fries		Medium	15 to 30 minutes	Place in aluminum foil pan. Grill, stirring occasionally.
MEATS				
Beef				
Hamburgers	1/2 to 3/4 inch	Medium	10 to 18 minutes	Grill, turning once when juices rise to the surface. Do not leave hamburgers unattended since a flare-up could occur quickly.
		High	8 to 15 minutes	
Steaks				

FOOD	WEIGHT OR THICKNESS	FLAME SIZE	APPROXIMATE TIME	SPECIAL INSTRUCTIONS AND TIPS
Rib,				
Tenderloin,				
Porterhouse,				
T-Bone, Sirloin				
Rare	1 inch	High	8 to 14 minutes	Remove excess fat from edge. Slash remaining fat at 2-inch intervals. Grill, turning once.
	1-1/2 inch	High	11 to 18 minutes	
Medium	1 inch	Medium to	12 to 22 minutes	
	1-1/2 inch	High	16 to 27 minutes	
Well-done	1 inch	Medium	18 to 30 minutes	
	1-1/2 inches	Medium	16 to 35 minutes	
Lamb				
Chops & Steaks				
Rare	1 inch	High	10 to 15 minutes	Remove excess fat from edge. Slash remaining fat at 2-inch intervals. Grill, turning once.
	1-1/2 inch	High	14 to 18 minutes	
Medium	1 inch	Medium to	13 to 20 minutes	
	1-1/2 inch	High	18 to 25 minutes	
Well-done	1 inch	Medium	17 to 30 minutes	
Pork Chops	1 inch	Medium	15 to 40 minutes	Remove excess fat from edge. Slash remaining fat at 2-inch intervals. Grill, turning once. Cook well done.
Well-done	1-1/2 inches	Medium	25 to 60 minutes	
Ribs		Medium	40 to 60 minutes	Grill, turning occasionally. During last few minutes brush with barbecue sauce, turn several times.
Pork				
Ham steaks				
(precooked)	1/2 inch slices	High	4 to 8 minutes	Remove excess fat from edge. Slash remaining fat at 2-inch intervals. Grill, turning once.
Hot dogs		Medium	5 to 10 minutes	Slit skin. Grill, turning once.
POULTRY				
Broiler/fryer	2 to 3 pounds	Low or	1 to 1-1/2 hours	Place skin side up. Grill, turning and brushing frequently with melted butter, margarine, oil or marinade.
Halved or		Medium	40 to 60 minutes	

Quartered well-done				
Breasts well-done		Medium	30 to 45 minutes	
FOOD	WEIGHT OR THICKNESS	FLAME SIZE	APPROXIMATE TIME	SPECIAL INSTRUCTIONS AND TIPS
FISH AND SEAFOOD				
Steaks				Grill, turning once. Brush with melted butter, margarine or oil to keep moist.
Halibut	3/4 to 1 inch	Medium to	8 to 15 minutes	
Salmon		High		
Swordfish				
Whole				
Catfish	4 to 8 ounces	Medium to	12 to 20 minutes	Grill, turning once. Brush with melted butter, margarine or oil.
Rainbow trout		High		

GRILL RECIPE SUGGESTIONS

BBQ SALMON

2 large salmon steaks
2 tbs. Oil
Salt & pepper
2 oz. thin bacon slices
2 tbs. Butter
1 tbs. Lemon juice
Spring of parsley
Lemon wedges

Preheat the BBQ.

Brush the steaks with oil and season with salt and pepper. Place on BBQ grill and cook for 10 minutes, turning steaks over halfway cooking time.

Meanwhile fry the bacon in a pan on the side burner. Drain on paper towels. Meld the butter in a small saucepan taking care not to discolor it. Arrange the fish and bacon on serving plates. Pour the butter over and sprinkle with lemon juice. Garnish with parsley springs and lemon wedges. Serve with boiled potatoes tossed in

BAKED CHILI CORN

6 medium ears corn, husked
3 tbs. Butter or margarine, melted
Dash ground cumin
Dash ground coriander

About ½ hour before cooking, turn the butter on for grill. Place each corn on a heavy-duty foil. In a bowl, combine remaining ingredients. Mix well. Brush 1-1/2 tsp. Butter mixture over each ear. Close foil and fold up ends to seal. Place on grill. Cook, turning packets occasionally 10 to 12 minutes or until cooked through.

TANGY SEAFOOD KABOBS

1 lb. Large shrimp, shelled & deveined
¾ lbs. sea scallops
2/3 c. chili sauce

butter and sprinkled with chopped parsley and a crisp lettuce salad.

Note: Substitute catfish, halibut or cod for salmon.

PORK CHOPS

4 Pork chops
Marinade
1 large onion
2 tbs. lemon juice or vinegar
2 tbs. oil
½ tsp. powdered mustard
2 tsp. Worcestershire sauce
½ tsp. freshly ground black pepper
1 tsp. sugar
½ tsp. paprika
1 clove garlic
Peel, grate onion, add rest of the ingredients except the pork chops. Mix well. Pour over chops and marinate one hour in a cool place. Turn the BBQ grill on full. Heat 10 minutes. BBQ the chops brushing with the marinade occasionally. Serve with mixed salad, dressed with vinaigrette flavored with fresh dill.
¼ c. cider vinegar
3 tbs. chopped parsley
1 tbs. vegetable oil
1 tbs. Worcestershire sauce
½ tsp. prepared horseradish
1 clove garlic, minced
1 20 oz. Can pineapple chunks in juice, drained

In medium bowl, combine shrimp and scallops. In small bowl combine chili sauce and next six ingredients. Pour over seafood. Toss to coat. Cover, refrigerate 2 hours.

Half hour before cooking, turn the burner to the grill on full. Drain seafood reserving marinade. On each of twelve 10" skewers, thread 2 shrimps and 2 scallops, alternating with pineapple chunks. Place skewers on grill. Cook 7-10 minutes, often basting and turning.

BARBECUED LONDON BROIL

4 to 6 servings

¾ c. Italian dressing
1 tsp. Worcestershire sauce
1 tsp. dry mustard
¼ tsp. thyme, crushed
1 medium onion, sliced
1 pound flank steak, scored
2 tbs. butter, melted

Combine first 4 ingredients, add onion and marinade flank steak with it. Refrigerate at least 4 hours or overnight. Remove steak and grill on your preheated BBQ grill. Grill 5 to 7 minutes on each side basting frequently with the marinade. In the meantime sauté onions from the marinade in butter in a skillet on your side burner for 3 minutes. To serve, slice steak diagonally into thin slices, sprinkle onions over top. Garnish with vegetable kabobs.

BARBECUED POTATOES and CHEESE

1-1/2 cups shredded cheddar cheese
1 can (10-3/4 oz.) condensed cream of mushroom soup
1/3 cup milk
2 tbs. barbecue sauce
¼ tsp. oregano
¼ tsp. salt
1/8 tsp. pepper
4 cups thinly sliced potatoes (4 medium-sized potatoes)

Preheat grill. Combine cheese, condensed soup, milk, BBQ sauce, oregano, salt and pepper in a large mixing bowl. Stir in potatoes until well coated. Turn into well buttered 1-1/2 quart rectangular baking dish. Cover dish with aluminum foil. Bake covered 25 minutes on medium with the lid of your BBQ grill closed. Remove

foil and continue baking 15 minutes longer or until potatoes are tender. Let stand 5 minutes before serving.

VEGETABLE KABOBS

3 medium-sized zucchini
12 cherry tomatoes
12 fresh mushrooms
Grated Parmesan cheese

Parboil whole zucchini 5 minutes on your side burner or until just tender. Drain and cut into 1/2 inch slices. Thread zucchini, tomatoes and mushrooms alternately on each of six skewers. Brush with marinade made of Italian dressing, Worcestershire sauce, mustard and thyme. Grill 5 to 7 minutes turning and basting occasionally. Sprinkle liberally with Parmesan cheese.

FAJITAS

1-1/2 lb. flank steak or boned chicken breasts
2 tbs. oil
1/2 cup lime juice
1/2 tsp. salt
1/2 tsp. celery salt
1/4 tsp. garlic powder
1/2 tsp. pepper
1/4 tsp. oregano
1/4 tsp. cumin
Flour tortillas lemon

Pound flank steak to 1/4 inch thickness or flatten chicken breasts. Mix oil, lime juice and seasonings in a zip lock bag. Add meat and shake bag to coat the meat. Refrigerate overnight or at least 6 to 8 hours. Wrap tortillas in foil. Remove meat from marinade. Cook on a pre-heated gas grill for 5 to 8 minutes on each side. While meat is cooking, heat tortillas on grill. Slice meat across grain in thin slices. Place on hot platter. Squeeze lemon juice over. Wrap meat and any of the following toppings in tortillas: chopped tomatoes, guacamole, sour cream, taco sauce.

BEEF AND LAMB KABOBS

Serve 4
1/2 lb. boneless sirloin or beef cut into 1" cubes
1/2 lb. boneless loin of lamb cut into 1" cubes
2/3 c. water, divided
1/4 c. chopped onion
2 tbs. soy sauce
1/4 c. vegetable oil, divided
1 tbs. dark brown sugar
1 tbs. fresh lemon juice
2 cloves garlic, minced
1/4 tsp. ground cumin
1/4 tsp. ground coriander
1/4 tsp. ground turmeric
1/8 tsp. ground red pepper
1/8 tsp. ground ginger
1 red pepper cut into chunks
1 large banana, cut into chunks
8 small mushrooms
1/3 c. smooth peanut butter

In blender, process 1/3 c. water, onion, soy sauce, 2 tsp. oil and the next 8 ingredients until smooth. Pour over meat cubes and marinate about 4 hours, turning occasionally. Drain and reserve marinade. Onto to four 12" skewers alternately thread meat, pepper, banana and mushrooms. Preheat grill. Brush the kabobs with oil. Grill 7-8 minutes each side.

Bring marinade to boil on the side burner in a saucepan. Add remaining 1/3 c. water and peanut butter. Stir to blend. Heat through. If sauce gets too thick, add 1 tbs. water. Serve sauce with kabobs.

EGGPLANT CAVIAR

1 large eggplant
2 tbs. olive oil
2 tbs. wine vinegar
2 tbs. finely chopped onion
1/2 clove garlic, minced
1 medium tomato, chopped salt and pepper

Roast eggplant on gas grill over medium flame, turning occasionally until thoroughly cooked. This may take 30 minutes.

Remove from grill and cool for handling. Strip off the skin and chop eggplant finely. Add all the seasonings. Chill thoroughly and serve on toast.

CHICKEN TANDOORI STYLE

8 large chicken thighs or drumsticks
1 c. plain nonfat yogurt
1/2 c. lemon juice
2 tsp. salt
1/2 tsp. cayenne
1/2 tsp. black pepper
1/2 tsp. crushed garlic
1/2 tsp. grated ginger
1 tbs. corn oil

Combine all the ingredients in a large mixing bowl and marinate the chicken for 8 hours in the refrigerator. Drain the chicken and spread on the spit running the rod on the fleshier side of the bone.

Rotis using the rotis burner. Cook on medium high heat for 40 minutes basting occasionally with the remainder of the marinade mixture. Serve with sliced onions and lemon wedges.

SPARE RIBS

Marinade:
1 c. soy sauce
1/2 c. honey
1/2 c. vinegar
1/2 c. dry sherry
2 tsp. chopped garlic
2 tsp. sugar
1 c. water
1 chicken bouillon cube
1 can beer for basting sauce

Marinate ribs for 3 hours. Use marinade for basting by adding beer to it. Place pan under the ribs and baste frequently. To cook ribs select lean, meaty ribs and accordion pleat them with your spit. Slide four prong meat hook down the length of spit and tighten. At the beginning of the rack and to its center, penetrate the second rib with the pointed end of the spit and push it between the

meat. Skip a couple and continue the process until the entire rack is accordion pleated. Fasten the second meat hook into the rack. Turn your rotis burner on high. Rotis for 50 minutes or until done.

PORK ROAST

Apple cider vinegar basting sauce:

1 c. apple cider vinegar

6 oz. water

½ stick butter

Salt, pepper, parsley and garlic seasoning

2 oz. lemon juice

10 lbs. pork roast

Time: 1-1/2 hours to 2 hours

Bring pork to room temperature before placing it on the spit rod.

Place on the rod and test for balance. Light rotis burner. Turn control knob to high. Use the above basting sauce for rotisserie.

TURKEY

12 lb. turkey

Beer basting sauce:

1 can beer

12 oz. water

1 stick butter

1 tsp. salt

1 tsp. pepper

½ tsp. garlic flakes

1 tsp. parsley

Thaw the bird completely. Wash inside out. Securely tie the legs and wings. Light rotis burner. Turn to high. Combine all the ingredients for basting sauce in a shallow pan. Place it under the turkey 15 to 20 minutes. Cook for approximately 3 hours. The basting sauce combined with turkey drippings makes a delicious gravy.

LIMITED WARRANTY
MODEL 720-0070
STAINLESS STEEL OUTDOOR GAS GRILL

Virco Associates Inc. warrants to the original consumer purchaser of each Outdoor Gas Grill that when subject to normal residential use, it is free from defects in workmanship and materials for the periods specified below. This warranty excludes grills used in rental or commercial applications. There will be a shipping and handling charge for the delivery of the warranty part(s).

Component	Warranty Period:
Burners:	2 Years
Stainless Steel Flame Tamer:	1 Years
Stainless Steel Cooking Grids:	1 Years
Valves:	1 Year
Frame, Housing, Cart, Control Panel, Igniter, and Related Parts:	1 Year
All Stainless Steel Parts	1 Years

Our obligation under this warranty is limited to repair or replacement, at our option, of the product during the warranty period. The extent of any liability of *Virco Associate Inc.* under this warranty is limited to repair or replacement. This warranty does not cover normal wear of parts, damage resulting from any of the following: negligent use or misuse of the product, use on improper fuel/gas supply, use contrary to operating instructions, or alteration by any person other than our factory service center. The warranty period is not extended by such repair or replacement.

Warranty claim procedure: If you require service or parts for your grill, please contact our Warranty Service Center for factory direct assistance. Our hours of operation are 8 AM to 5 PM PST. Our number is 1-909-598-8799 and our FAX number is 1-909-598-7699. Please direct all correspondence to: *Virco Associate, Inc. 145 Brea Canyon Road, Walnut, CA 91789 ATTN: Warranty Service Center.*

Product repair as provided under this warranty is your exclusive remedy. *Virco Associate, Inc.* shall not be liable for any incidental or consequential damages for breach of any express or implied warranty on its products. Except to the extent prohibited by applicable law, any implied warranty or merchantability or fitness for a particular purpose on this product to the duration of the above warranty. Some states do not allow the exclusion or limitation of incidental or consequential damages, or allow limitations on how long an implied warranty lasts, so the above limitations or exclusions may not apply to you. This warranty gives you specific legal rights, and you may have other rights, which vary from state to state.